

P-14/P-17
ENFIELD RIFLE

★ RESTRICTED

ORDNANCE FIELD SERVICE

BASE SHOP DATA



U. S. Rifle, Cal. .30, M1917

PREPARED UNDER THE DIRECTION OF THE
CHIEF OF ORDNANCE

ROCK ISLAND ARSENAL - FEB., 1943

Ordnance Field Service Base Shop Data

U. S. Rifle, Cal. .30, M1917

LIST OF CONTENTS

List Of References

General Information

* Conversion List Of Tool Drawings

<u>Item</u>	<u>R.S.D. NO.</u>
Assembly - - - - -	2
Dismantling - - - - -	1

* Dissemination of restricted matter—The information contained in restricted documents and the essential characteristics of restricted material may be given to any person known to be in the service of the United States and to persons of undoubted loyalty and discretion who are cooperating in Government work, but will not be communicated to the public or to the press except by authorized military public relations agencies. (See also paragraph 10 b, AR 385-2, 25 September 1942.)

* Replaces List Of Contents, Issue of February 1943

★ RESTRICTED

ORDNANCE FIELD SERVICE

BASE SHOP DATA



U. S. Rifle, Cal. .30, M1917

PREPARED UNDER THE DIRECTION OF THE
CHIEF OF ORDNANCE

ROCK ISLAND ARSENAL - FEB., 1943

★ **Dissemination of restricted matter**—The information contained in restricted documents and the essential characteristics of restricted materiel may be given to any person known to be in the service of the United States and to persons of undoubted loyalty and discretion who are employed in Government work, but will not be communicated to the public or to the press except by authorized military public relations agencies. (See also paragraph 14 b, AR 300-3, 28 September 1942.)

SMALL ARMS

USDIFLE
M19.7 CAL 30ASSEMBLING
USDIFLE M1917

SHEET

1

OF 14

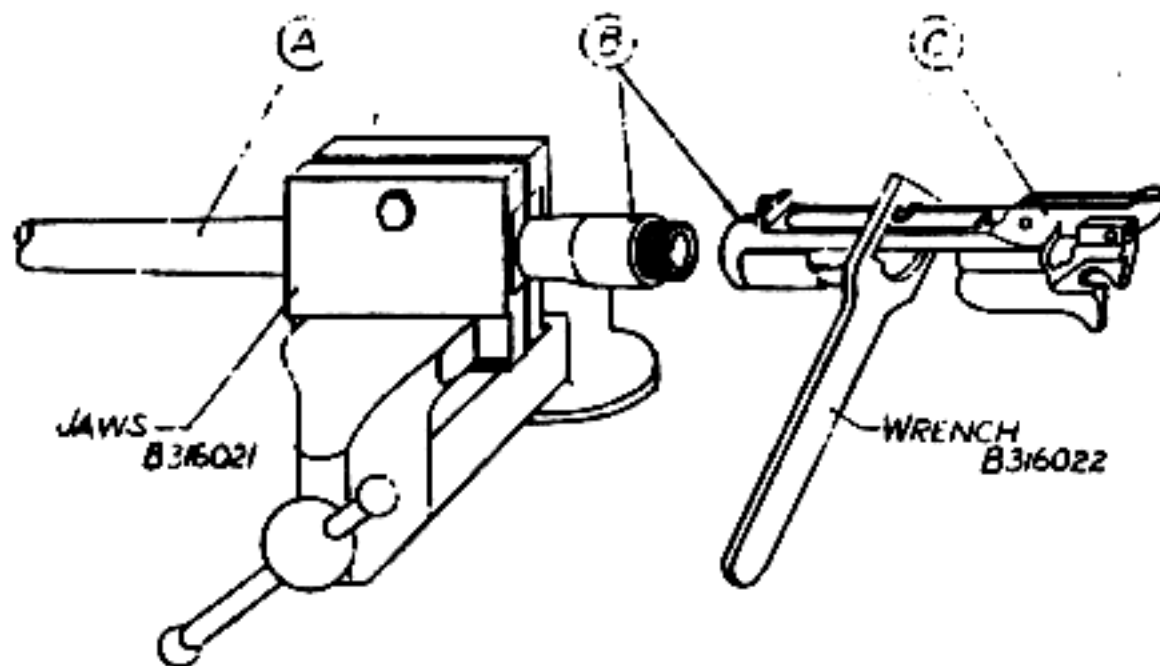
RECEIVER AND BARREL

- ① IF RECEIVER (C) OR BARREL (A) IS FOUND UNSERVICEABLE, AS INDICATED IN PREVIOUS SECTION, UNSCREW THE RECEIVER FROM BARREL (RIGHT HAND THREAD) WITH THE AID OF SPECIAL TOOLS, JAWS B316021 AND WRENCH B316022, AND REPLACE WITH NEW OR SERVICEABLE PARTS. BEST RESULTS IN ASSEMBLING RECEIVER TO BARREL ARE OBTAINED BY SELECTING THE PROPER COMBINATION, SO IT REQUIRES APPROXIMATELY 1/4" DRAW TO HAVE THE REFERENCE OR DRAW LINES (B) COINCIDE.

USDIFLE M1917-ASSEM 1(14)

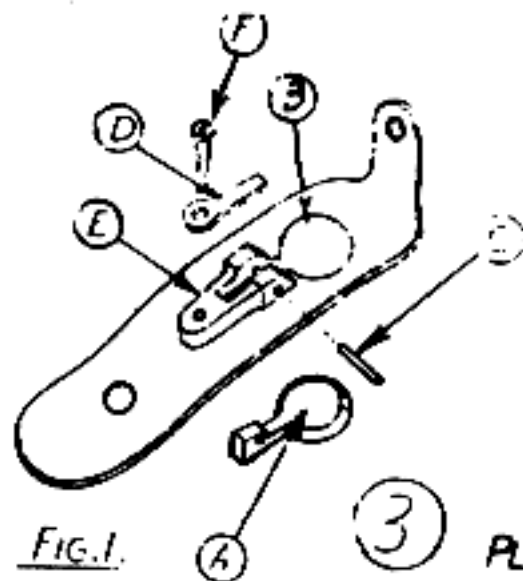

2

INSERT THE BUTT-PLATE CAP (A) INTO THE SEAT (B), AND TAP IN THE BUTT-PLATE PIN (C). PLACE THE BUTT-PLATE SPRING (D) ON THE SHOULDER (E) AND LOCK INTO PLACE WITH THE BUTT-PLATE SPRING SCREW (F).

FIG. 1.

3

PLACE BUTT-SWIVEL PLATE (G) INTO POSITION AT (H) AND FASTEN INTO PLACE WITH THE TWO BUTT-SWIVEL SCREWS (J) AND (K).

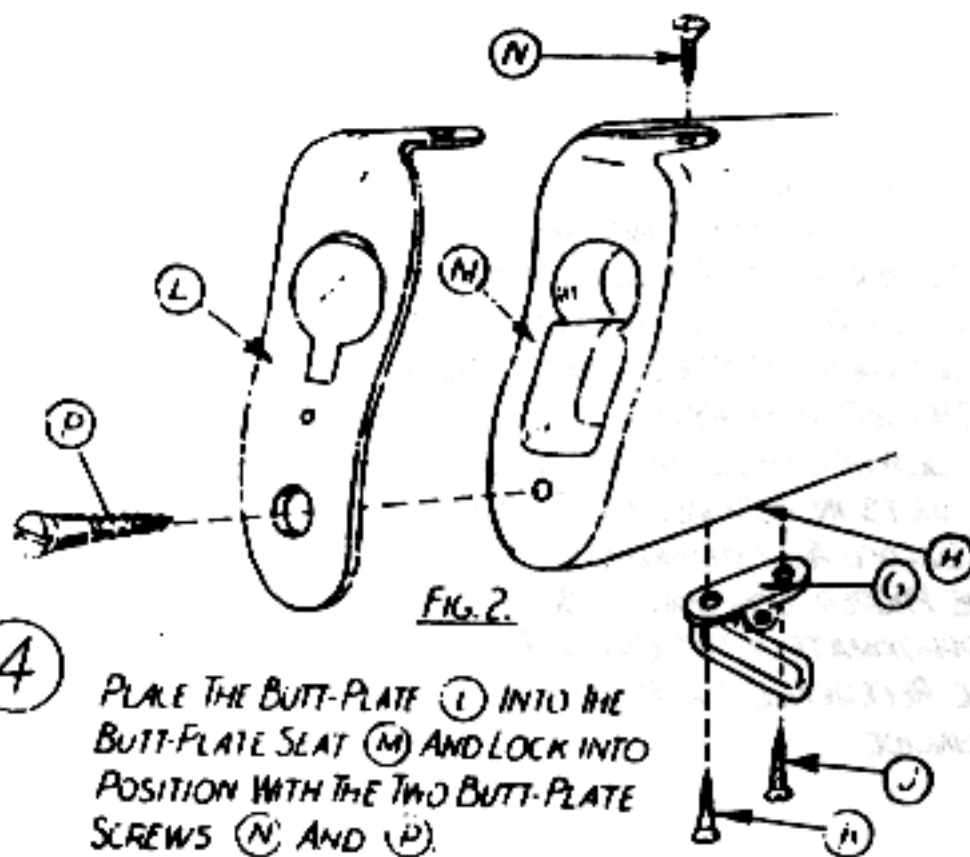

FIG. 2.

4

PLACE THE BUTT-PLATE (I) INTO THE BUTT-PLATE SLAT (M) AND LOCK INTO POSITION WITH THE TWO BUTT-PLATE SCREWS (N) AND (P).

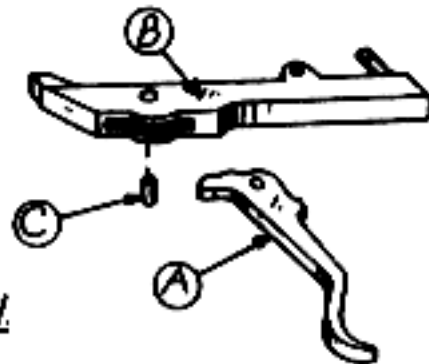

FIG. 1.

5 INSERT THE TRIGGER (A) INTO THE SEAR (B) AND TAP IN TRIGGER PIN (C).

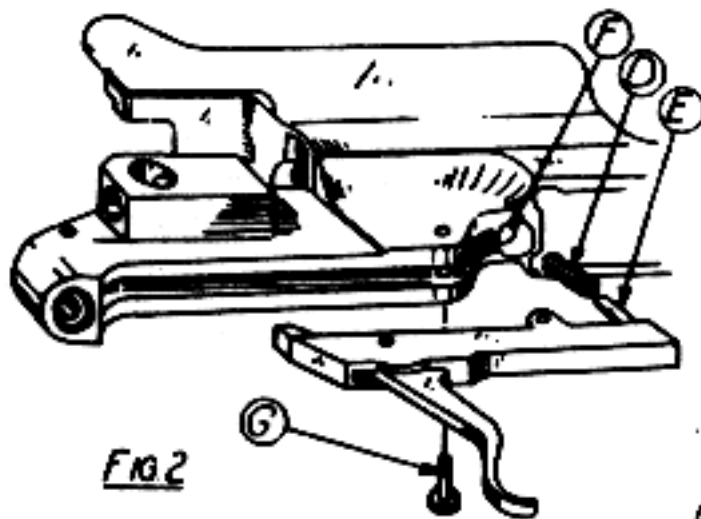

FIG. 2

6 PLACE THE SEAR SPRING (D) ON THE LUG (E) AND INSERT THE UNIT INTO THE HOUSING (F). LOCK THE UNIT INTO POSITION WITH THE SEAR PIN (G).

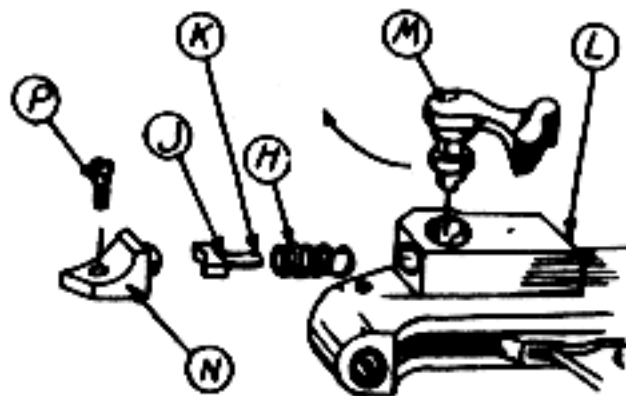
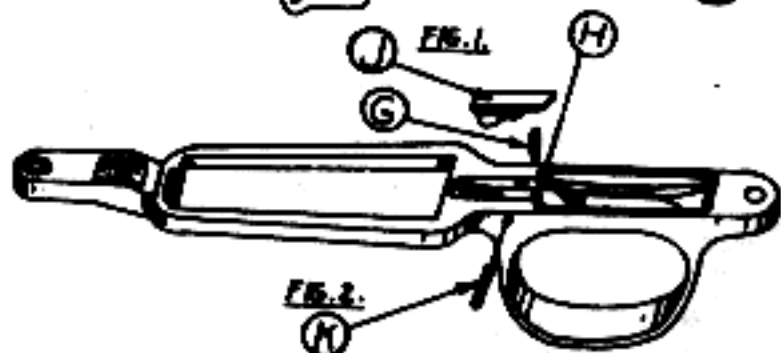
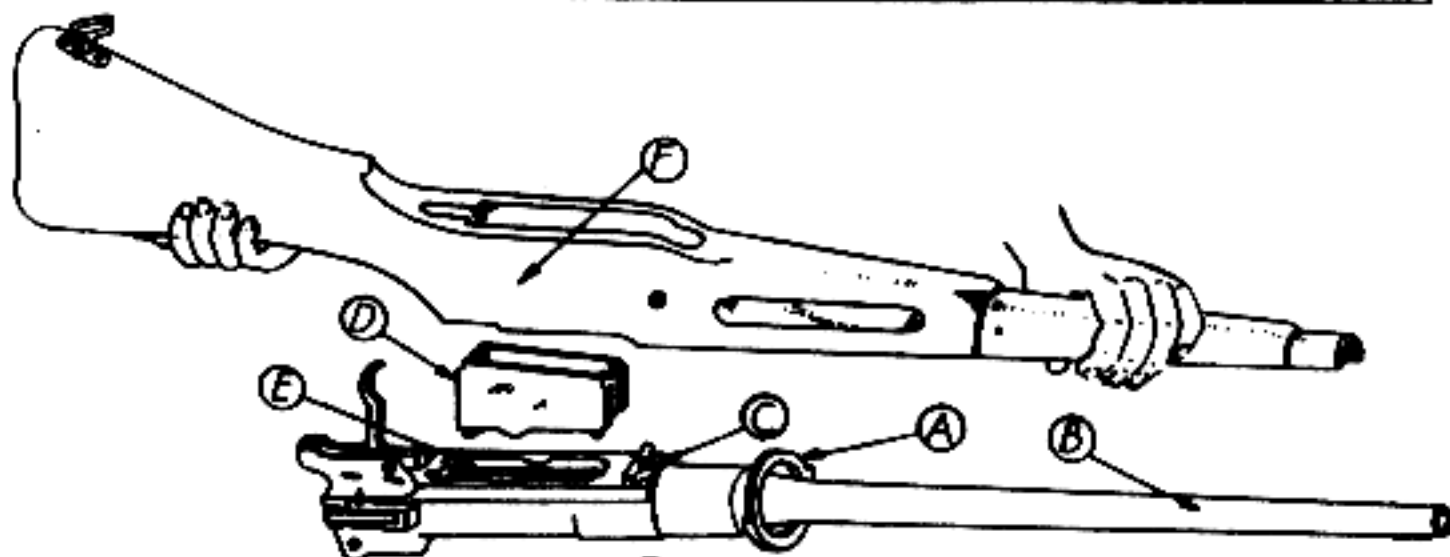

FIG. 3.

7 PLACE THE SAFETY LOCK SPRING (H) ON SAFETY LOCK PLUNGER (J) AND INSERT THE UNIT INTO THE HOUSING; PUSH WITH SCREWDROVER UNTIL END (K) IS PROTRUDING FROM END OF HOUSING AT POINT (L). HOLD END (K) WITH A PAIR OF PLIERS, THEN INSERT THE SAFETY LOCK (M) AS SHOWN IN FIG. 3, AND TURN IT CLOCKWISE A HALF TURN. PLACE THE SAFETY LOCK HOLDER (N) INTO POSITION AND FASTEN IT WITH SAFETY LOCK HOLDER SCREW (P).

SMALL ARMS USRIFLE M1917 CAL 30	ASSEMBLING USRIFLE, M1917	SHEET 4 OF 14
--	-------------------------------------	---------------------



8 SLIDE THE HAND GUARD RING (A) ON OVER THE BARREL (B) UNTIL IT RESTS AGAINST THE SHOULDER (C). PLACE THE MAGAZINE (D) INTO THE HOUSING (E) AS SHOWN IN FIG. 1. PLACE THE STOCK (F) ON OVER THE BARREL (B), BEING SURE THAT THE MAGAZINE (D) IS NOT DISTURBED FROM ITS SEAT.

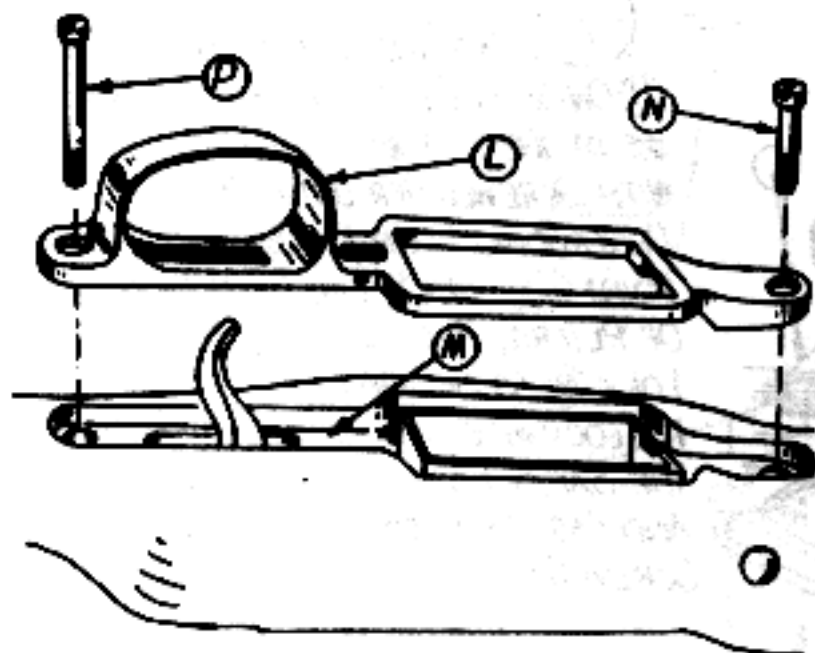

9 INSERT THE FLOOR PLATE SPRING (G) INTO ITS SEAT (I). PLACE THE FLOOR PLATE CATCH (J) INTO POSITION AND TAP IN THE FLOOR PLATE PIN (K).

10 PLACE THE GUARD (L) INTO THE SEAT (M) IN THE STOCK. FASTEN IN PLACE WITH THE FRONT GUARD SCREW (N) AND THE REAR GUARD SCREW (O).

FIG. 3.

11

SLIDE THE MAGAZINE SPRING (A) UNDER THE LUGS (B) ON THE FOLLOWER (C). FOLLOW SAME PROCEDURE TO ENGAGE THE SPRING WITH THE FLOOR PLATE (D).

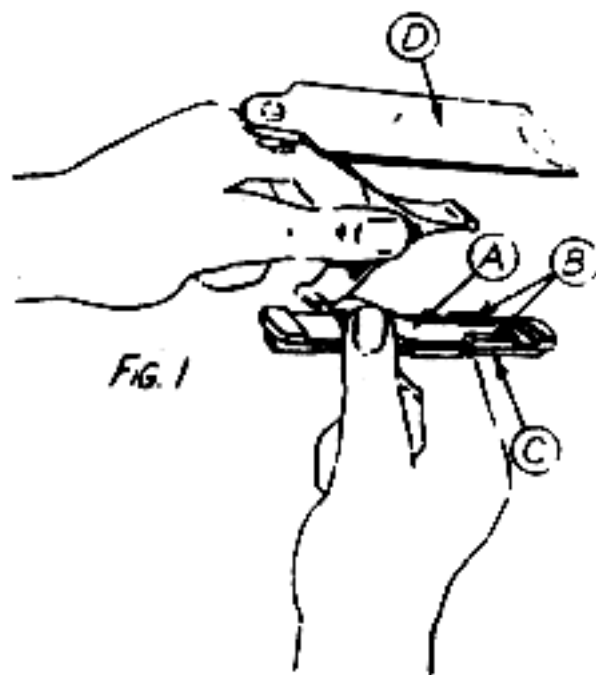

FIG. 1

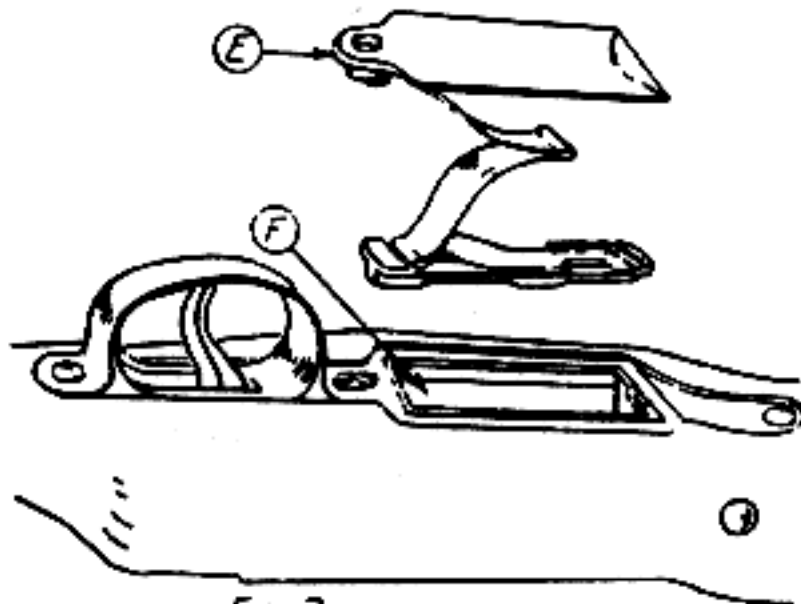

FIG. 2

12

LOWER THE FLOOR PLATE ASSEMBLY (E) INTO THE HOUSING (F) AS SHOWN IN FIGURE 2

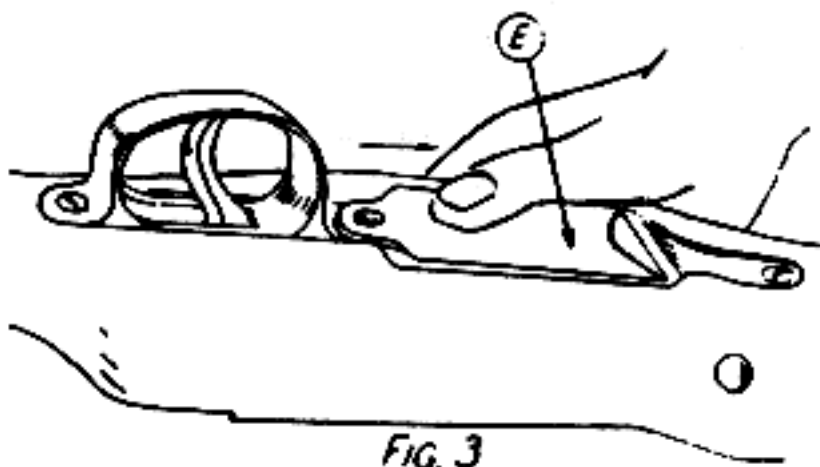

FIG. 3

13

TO LOCK THE FLOOR PLATE ASSEMBLY (E) INTO THE HOUSING, PRESS DOWN ON THE PLATE WITH THUMB, AND THEN PUSH FORWARD.

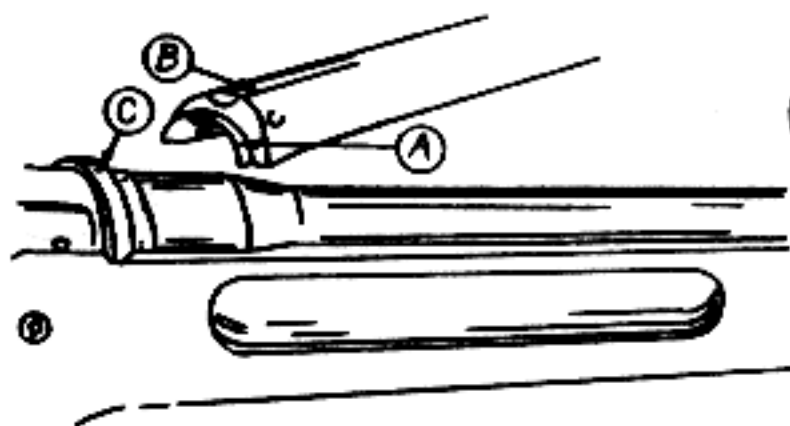

FIG. 1

- 14 PLACE SHOULDER (A) ON THE REAR HAND GUARD (B) UNDER THE HAND GUARD RING (C).

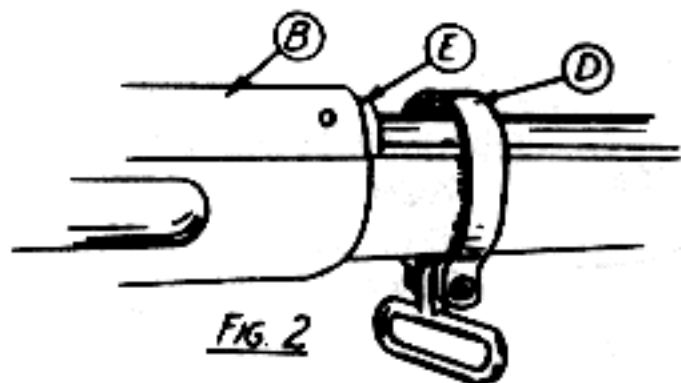

FIG. 2

- 15 SLIDE THE LOWER BAND (D) OVER THE BARREL UNTIL IT RESTS AGAINST THE SHOULDER (E) ON THE REAR HAND GUARD (B).

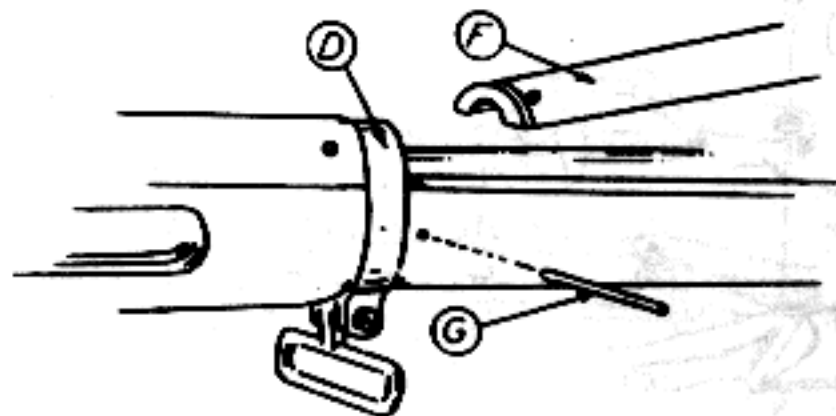

FIG. 3

- 16 PLACE THE FRONT HAND GUARD (F) UNDER THE LOWER BAND (D) AND TAP IN THE LOWER BAND PIN (G).

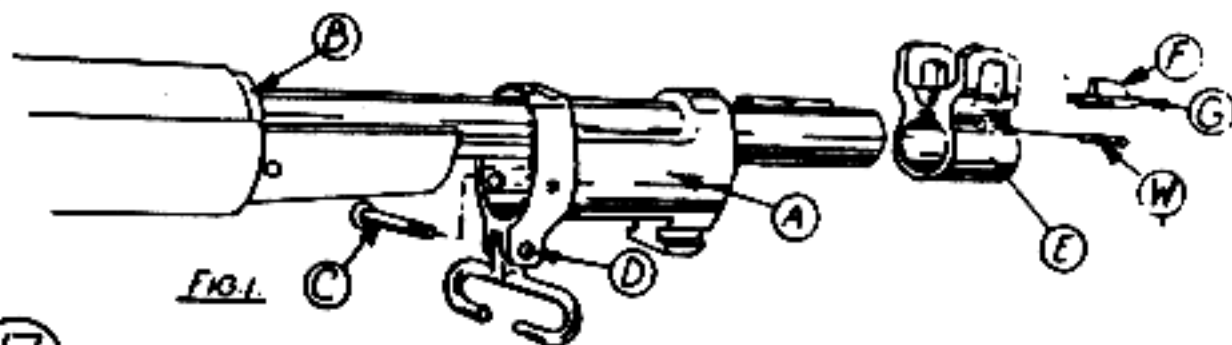

FIG. 1

17 TAP ON THE UPPER BAND (A) UNTIL IT RESTS AGAINST THE FRONT HAND GUARD (B). SCREW IN THE UPPER BAND SCREW (C), AND TIGHTEN THE STOCKING SWIVEL SCREW (D). USING A SOFT HAMMER, TAP ON THE FRONT SIGHT CARRIER (E); DRIVE IN THE CARRIER PIN (W). TAP THE FRONT SIGHT (G) INTO ITS SEAT IN THE CARRIER (E).

NOTE: BE SURE THAT THE ROUND EDGE (F) FACES THE MUZZLE OF THE GUN.



FIG. 2

18 TO ASSEMBLE THE PEEP SIGHT ASSEMBLY (V), PLACE THE CATCH SPRING (F) AGAINST THE SHOULDER (J), FOLLOWED BY THE CATCH (K). TAP IN THE CATCH PIN (L).

19 SLIDE THE PEEP SIGHT ASSEMBLY (V) ON THE REAR SIGHT LEAF (M). SCREW IN THE STOP SCREW (N).

20 FASTEN THE REAR SIGHT BASE SPRING (P) INTO ITS SEAT WITH THE SPRING SCREW (Q).

PLACE THE REAR SIGHT LEAF (M) INTO POSITION SO THAT THE HOLE (R) WILL BE IN LINE WITH THE HOLE (S). TAP IN THE JOINT BOLT (T) AND LOCK WITH THE NUT (U).

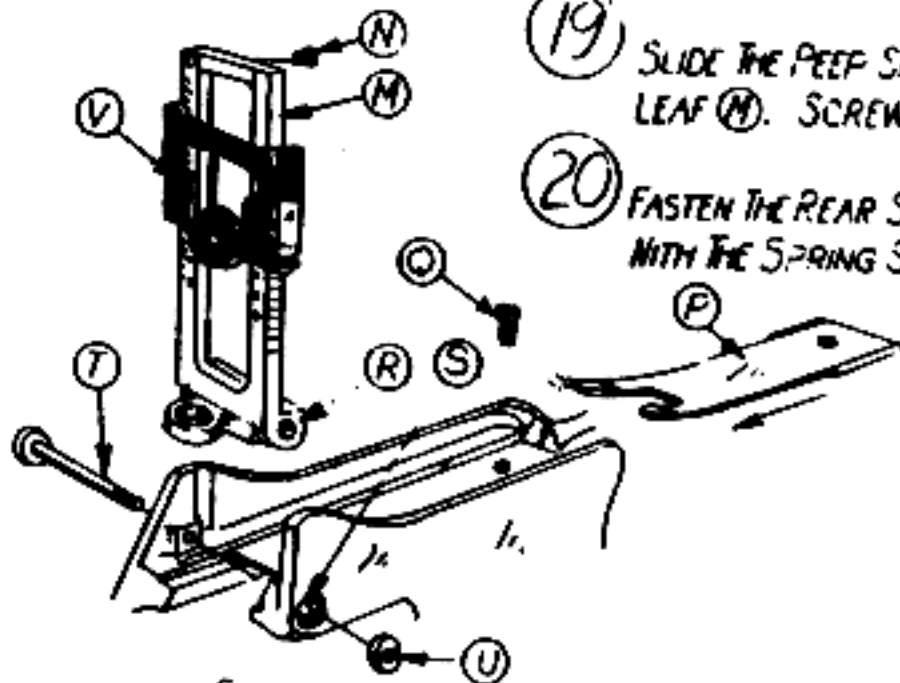
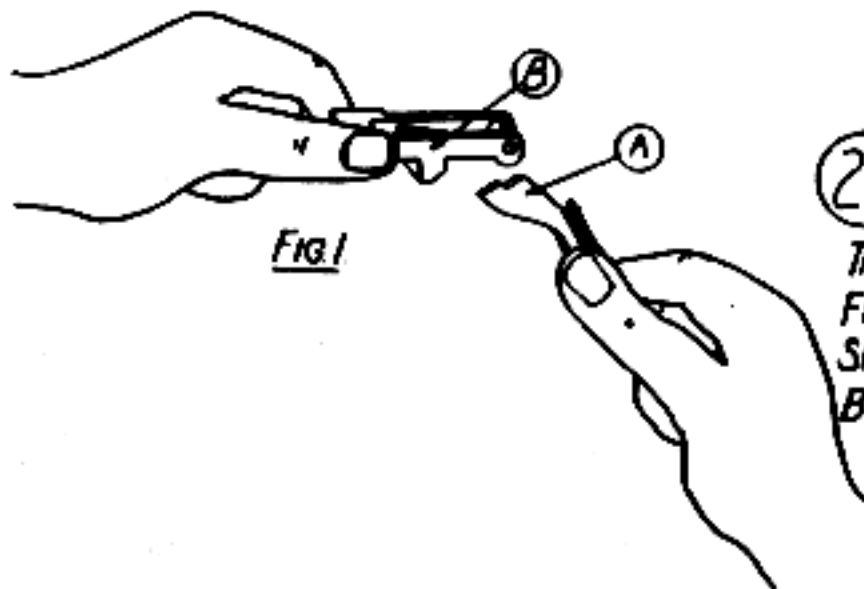
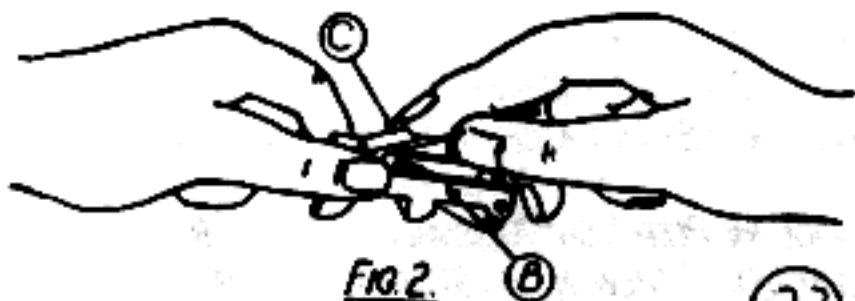

FIG. 3



21 PLACE THE EJECTOR (A) INTO THE BOLT STOP (B) AS SHOWN IN FIG. 1. PRESS THE BOLT STOP SPRING (C) DOWN FIRMLY INTO THE BOLT STOP (B).



22 INSERT THE SPRING SEAT (D) INTO POSITION AT (E). FASTEN THE BOLT STOP (B) INTO PLACE WITH THE BOLT STOP SCREW (F).

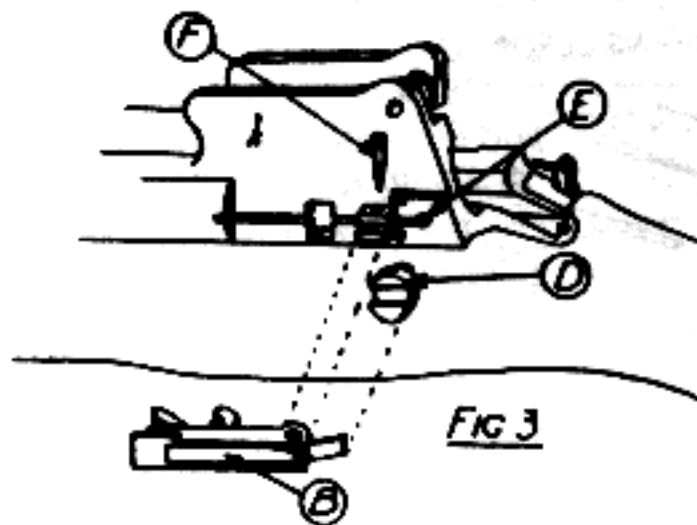

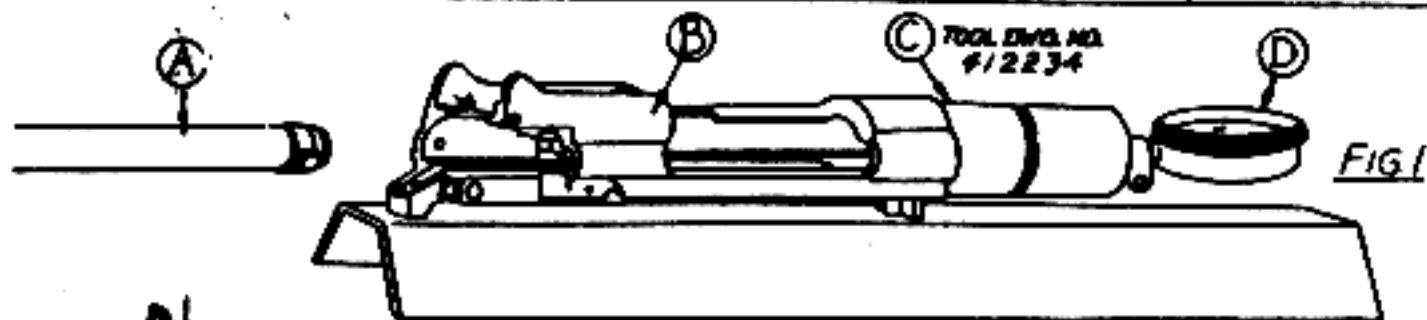

23 INSERT THE MINIMUM TEST BOLT (A) INTO RECEIVER (B) OF TOOL (C) AND SET INDICATOR (D) AT '0'. REMOVE TEST BOLT (A) AND INSERT RIFLE BOLT INTO RECEIVER (B). IF INDICATOR READS MORE THAN MINUS .001, REJECT BOLT

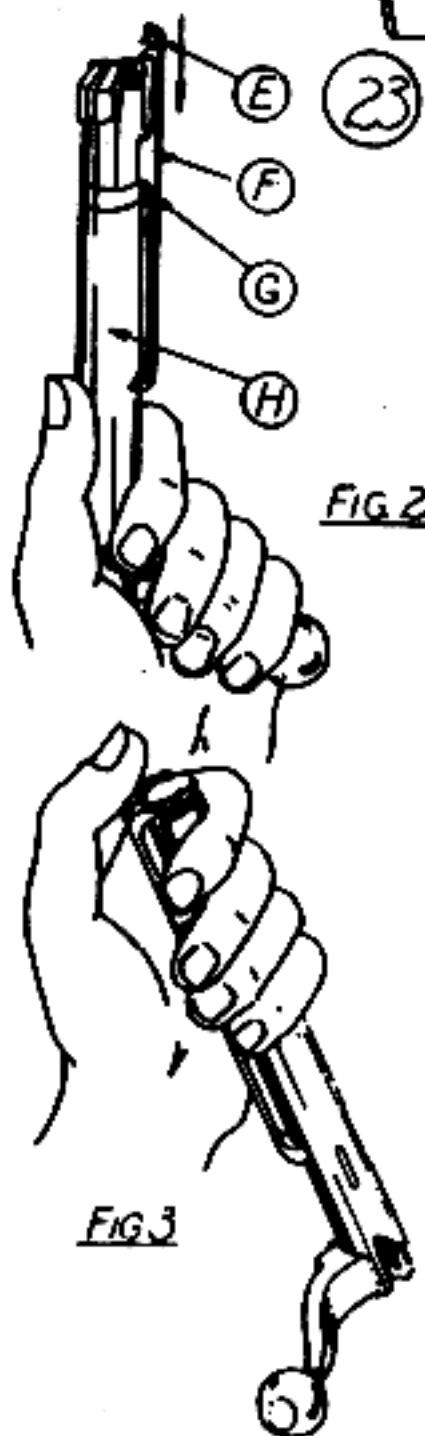

24 INSPECT THE LIDS (E) OF EXTRACTOR (F), NOTING THEIR CONDITION AS TO WEAR AND MUTILATIONS. EXTRACTOR (F) SHOULD HAVE A SLIGHT BEND, GIVING IT SPRING TENSION.

INSPECT THE SHELL SEAT IN BOLT (H). STONE DOWN ALL HIGH SPOTS AND REMOVE ALL DUST.

NOTE: THE EJECTION OF SHELLS IS A VERY IMPORTANT OPERATION; THEREFORE EXTRACTOR (F) AND BOLT (H) SHOULD BE INSPECTED VERY THOROUGHLY.

25 SLIDE THE EXTRACTOR (F) ONTO THE LUG (G) AS SHOWN IN FIG. 2. GRASP THE BOLT AS SHOWN IN FIG. 3, AND PUSH THE EXTRACTOR DOWN WITH THE THUMB.

SMALL ARMS
 USRIFLE
 M1917 CAL.30

ASSEMBLING
 USRIFLE M1917

SHEET

10
 OF 14

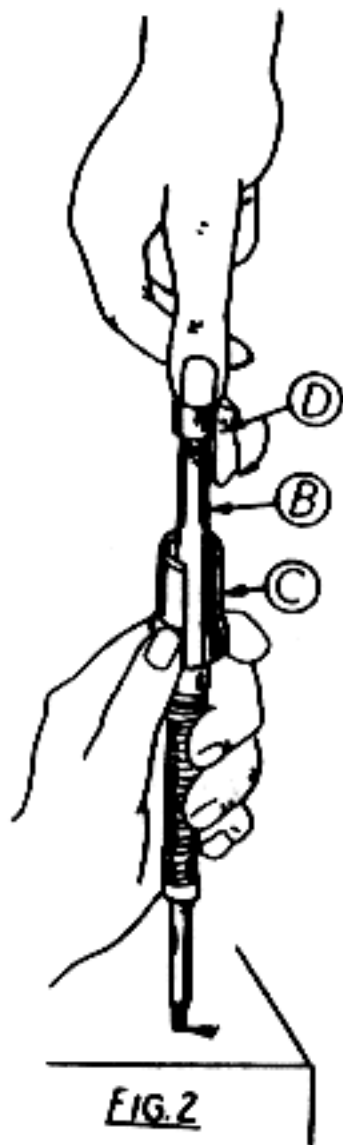

(26) PLACE THE SPRING (A) ON THE STRIKER (B), FOLLOWED BY THE SLEEVE (C). COCKING PIECE ASSEMBLED IN FOLLOWING OPERATION.

(27) GRASP THE SLEEVE (C) AND PULL DOWN, AS IN FIG. 2. PLACE THE COCKING PIECE (D) OVER THE END OF THE STRIKER (B) AS SHOWN, AND TURN CLOCKWISE.

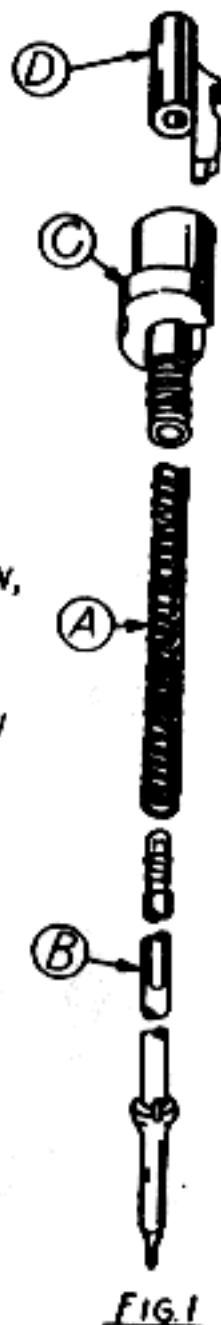

SMALL ARMS U.S. RIFLE M1917-CAL 30	ASSEMBLING U.S. RIFLE, M1917	SHEET 11 OF 19
---	--	----------------------

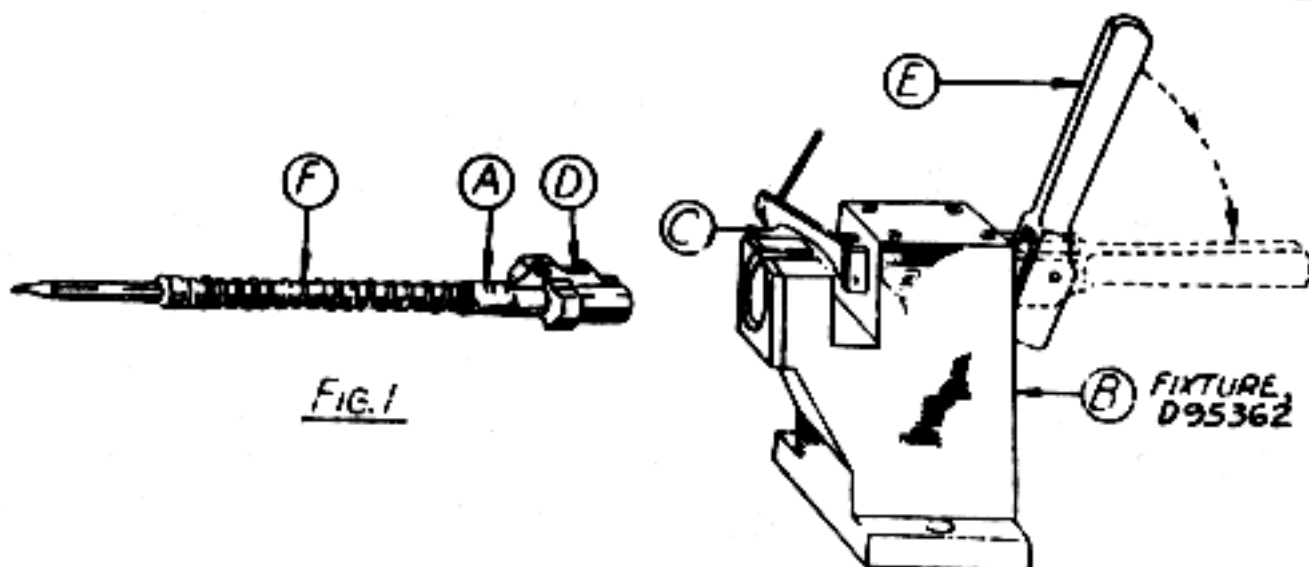

28. INSERT FIRING PIN ASSEMBLY (A) INTO FIXTURE (B) SO CATCH (C) ENGAGES FIRING PIN ASSEMBLY (A) AT (D). PULL HANDLE (E) OF FIXTURE (B) TO HORIZONTAL POSITION, SECURING ASSEMBLY (A) AND COMPRESSING SPRING (F).

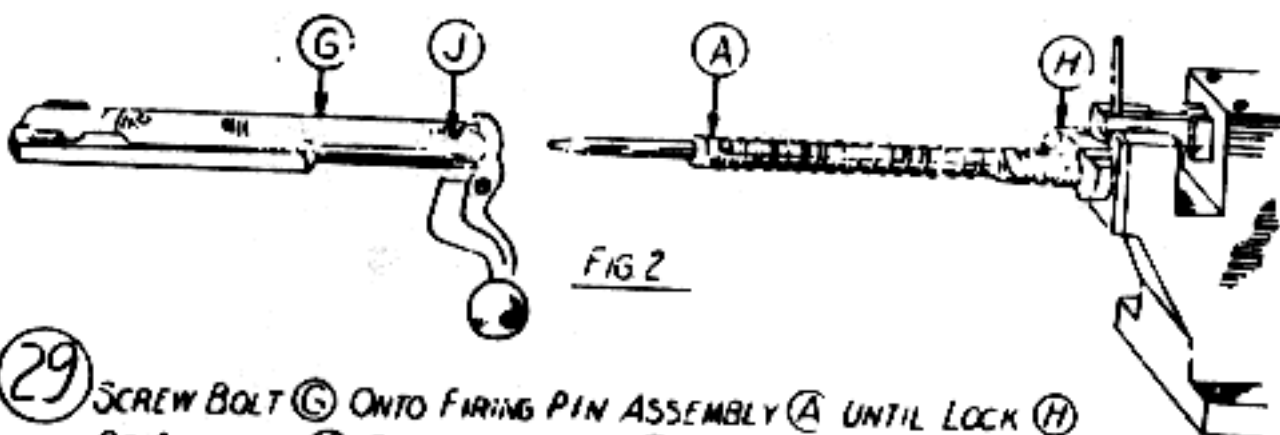

29. SCREW BOLT (G) ONTO FIRING PIN ASSEMBLY (A) UNTIL LOCK (H) OF ASSEMBLY (A) ENGAGES IN SEAT (J) OF BOLT (G). REMOVE THE COMBINED BOLT AND FIRING PIN ASSEMBLY FROM THE FIXTURE.

SMALL ARMS
 USRIFLE
 M1917-CAL.30

ASSEMBLING
 USRIFLE, M1917

SHEET
 12
 OF 14

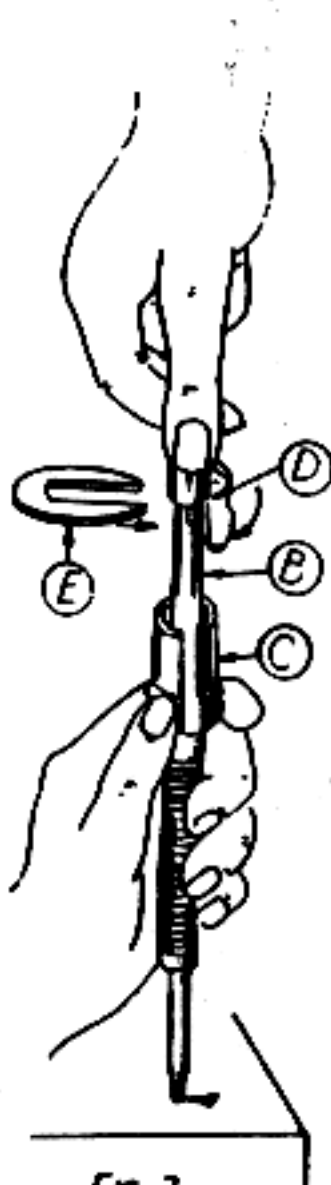

FIG. 2

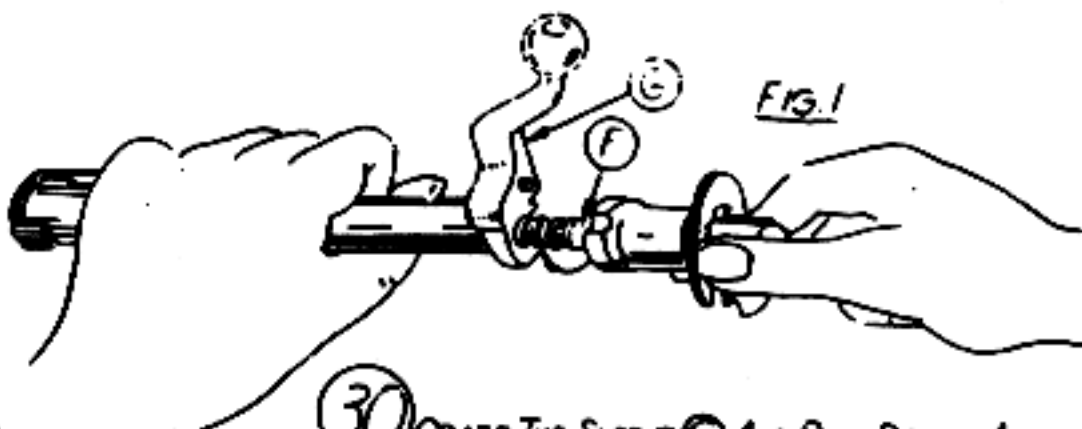

FIG. 1

- 30 GRASP THE SLEEVE (C) AND PULL DOWN, AS IN FIG. 2. PLACE THE COCKING PIECE (D) OVER THE END OF THE STRIKER (E) AS SHOWN, AND TURN CLOCKWISE. PLACE THE "C" WASHER (C) BETWEEN THE COCKING PIECE (D) AND THE SLEEVE (C).
- 31 SCREW THE ASSEMBLY (F) INTO THE BOLT (G).
- 32 WITH THE FIRING PIN IN FIRING POSITION, SLIDE STRIKER PROTRUSION GAGE (K) OVER THE STRIKER (L). THE .050" SHOULD NOT PASS OVER THE STRIKER (L). IF IT CLEARS, THE STRIKER IS NOT LONG ENOUGH; THEREFORE MUST BE REPLACED. THE .075" SHOULD CLEAR THE STRIKER (L); IF IT DOES NOT, THE STRIKER IS TOO LONG AND THEREFORE MUST BE SHORTENED TO PREVENT PUNCTURED PRIMER CUPS.



FIG. 3

115R-M1917-ASSEMBLING-20M

SMALL ARMS U.S. RIFLE M1917 CAL.30	ASSEMBLING U.S. RIFLE, M1917	SHEET 13 OF 14
---	--	-----------------------------

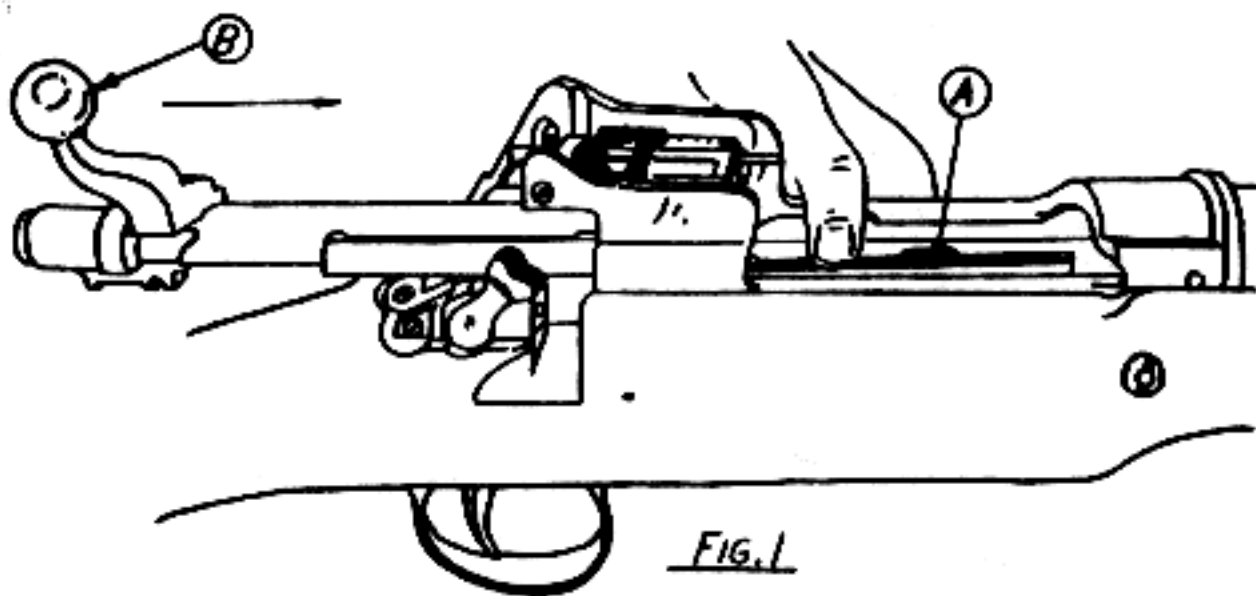

33 PRESS DOWN ON MAGAZINE FOLLOWER (A) WITH THUMB, AS SHOWN, AND CLOSE THE BOLT (B).

34 WHEN BOLT (B) CLOSSES, IT WILL AUTOMATICALLY COCK, AS SHOWN BY THE POSITION OF THE COCKING PIECE (C), IN FIG. 2. PULL TRIGGER (D) TO FIRE.

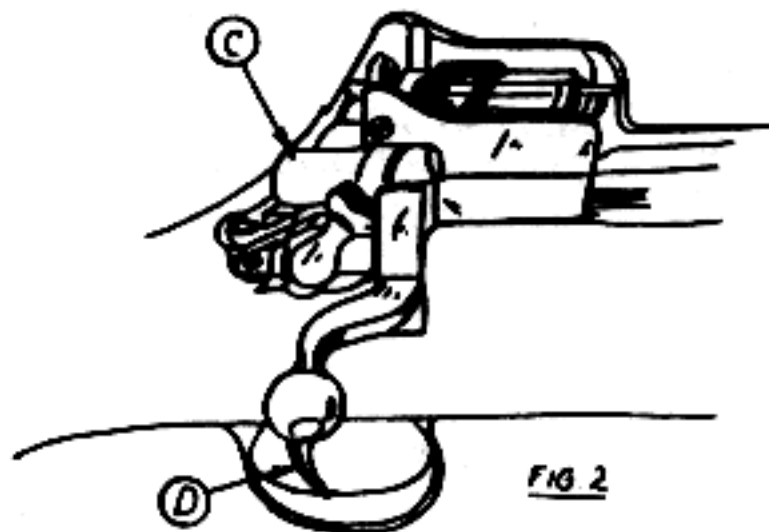

SMALL ARMS US RIFLE M1917-CAL 30	ASSEMBLING US RIFLE, M1917	SHEET 14 OF 14
--	-------------------------------	----------------------

ADJUSTING FRONT SIGHT

TOOLS REQUIRED

TOOL DWG NO	SHEET	OPER	DET
909220	1	1	C
909221	1	1	F
2800F4-34A	11	28	B
20-19-34D	12	32	K
20-19-34C	14	35	NOTE
412234	9	23	C

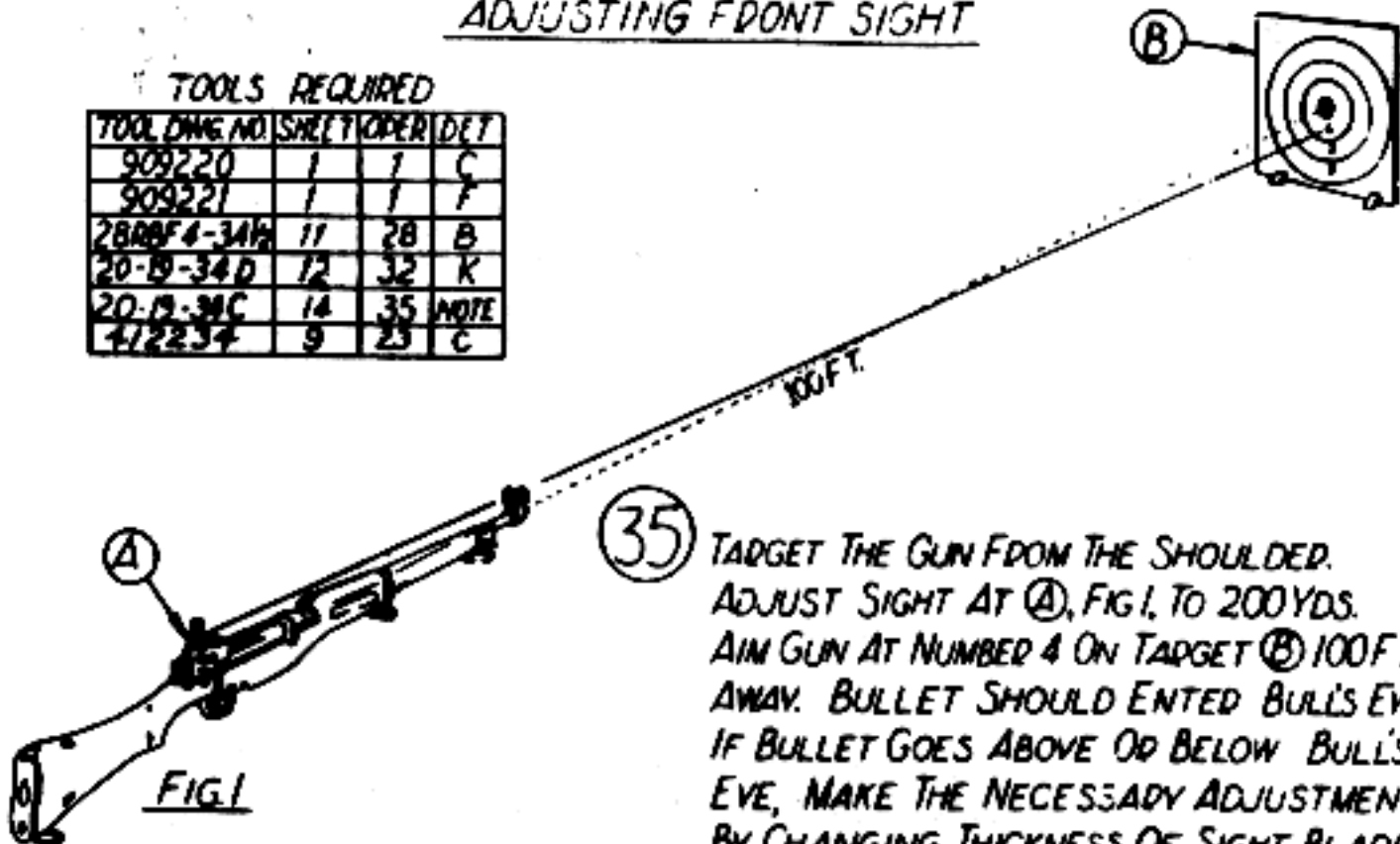

35 TARGET THE GUN FROM THE SHOULDER. ADJUST SIGHT AT (A), FIG. 1, TO 200 YDS. AIM GUN AT NUMBER 4 ON TARGET (B) 100 FT. AWAY. BULLET SHOULD ENTER BULL'S EYE. IF BULLET GOES ABOVE OR BELOW BULL'S EYE, MAKE THE NECESSARY ADJUSTMENTS BY CHANGING THICKNESS OF SIGHT BLADE (C), FIG. 2.

NOTE: THERE ARE ELEVEN DIFFERENT THICKNESSES OF SIGHT BLADES, RANGING FROM .135" TO .0985". IF BULLET GOES EITHER TO RIGHT OR LEFT OF BULL'S EYE, PLACE TOOL (D) OVER CARRIER (E) AND PUSH SIGHT BLADE (C) TO RIGHT OR LEFT BY TURNING HANDLES (F). STAKE SIGHT BLADE AT (G).

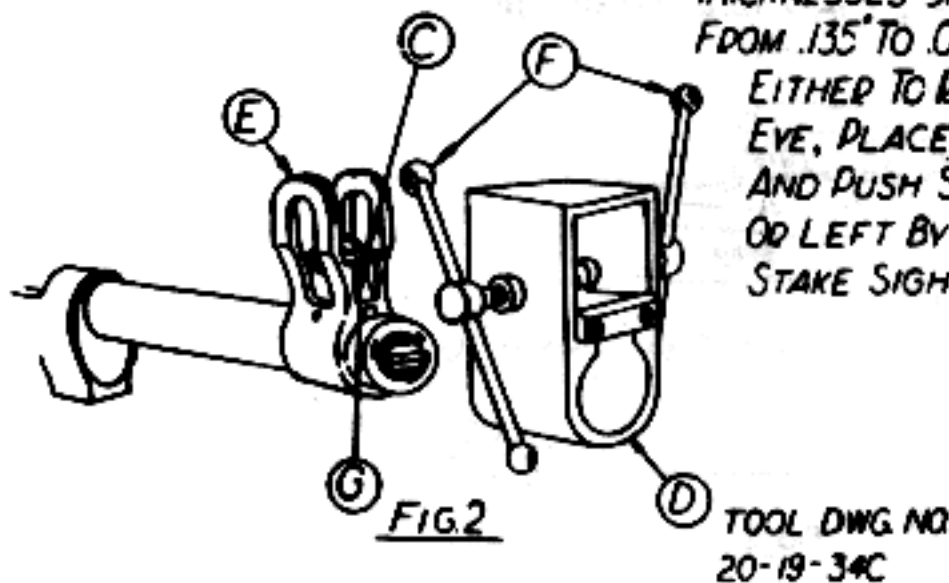

USR-M1917-ASSEMBLING(14)

★ RESTRICTED

ORDNANCE FIELD SERVICE

BASE SHOP DATA



U. S. Rifle, Cal. .30, M1917

PREPARED UNDER THE DIRECTION OF THE
CHIEF OF ORDNANCE

ROCK ISLAND ARSENAL - FEB., 1943

★ Dissemination of restricted matter—The information contained in restricted documents and the essential characteristics of restricted material may be given to any person known to be in the service of the United States and to persons of undoubted loyalty and discretion who are cooperating in Government work, but will not be communicated to the public or to the press except by authorized military public relations agencies. (See also paragraph 18 b, AR 200-5, 28 September 1942.)

Dismantling

U.S.G. No.

1

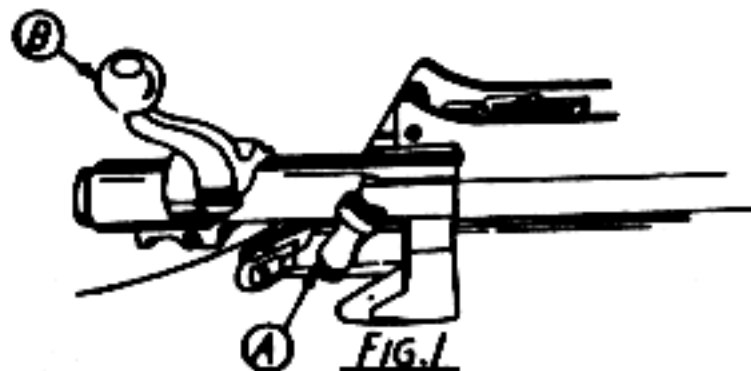

1 WITH SAFETY LOCK (A) FORWARD, LIFT UP ON BOLT HANDLE (B) AND PULL BOLT TO REAR. PUSH THE SAFETY

LOCK (A) ALL THE WAY TO REAR, AS SHOWN IN FIG. 2. CLOSE THE BOLT (B).

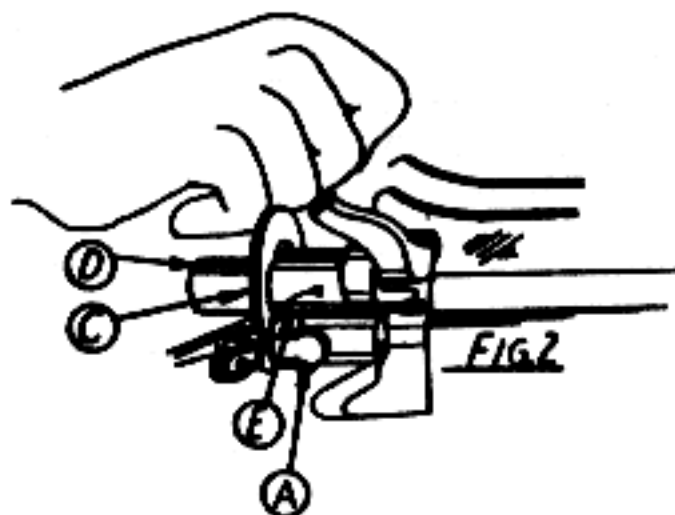

2 INSERT A SMALL PIECE OF METAL (C) BETWEEN COCKING PIECE (D) AND SLEEVE (E).

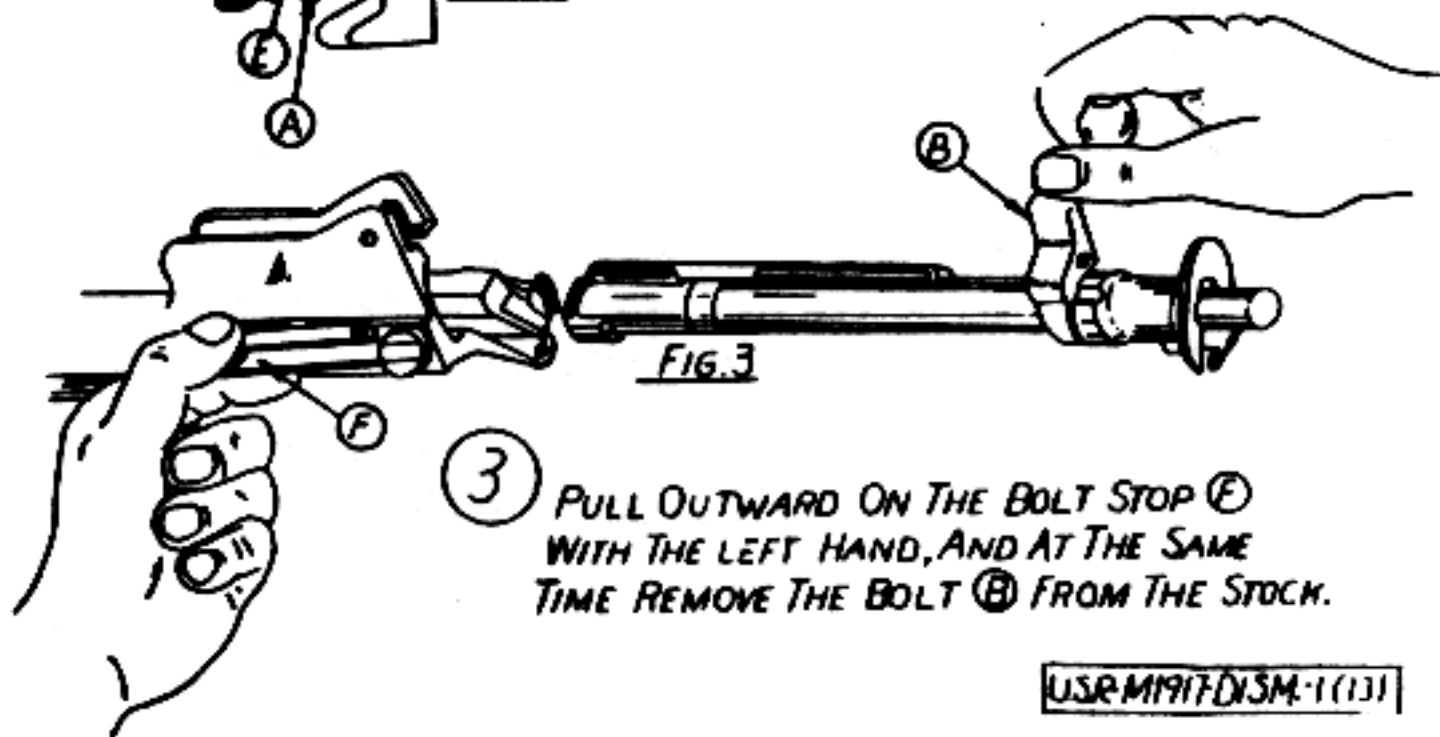

3 PULL OUTWARD ON THE BOLT STOP (F) WITH THE LEFT HAND, AND AT THE SAME TIME REMOVE THE BOLT (B) FROM THE STOCK.

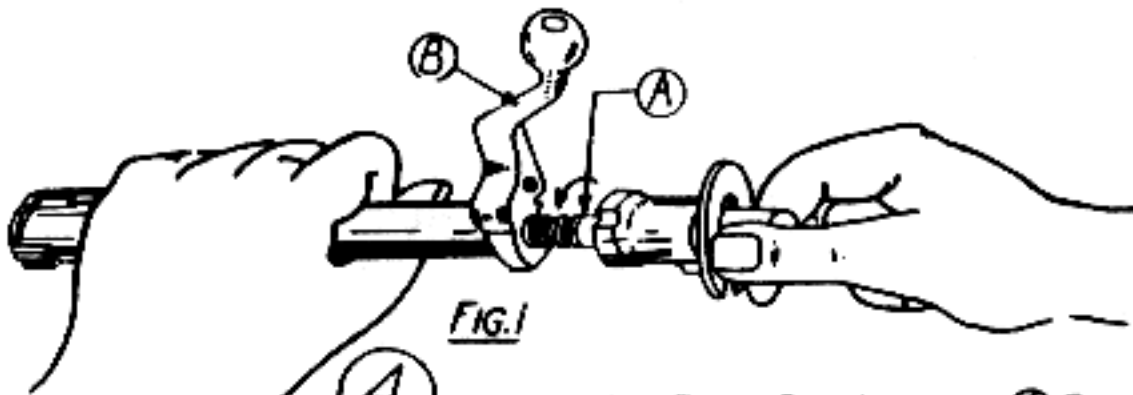

FIG. 1

4 UNSCREW THE FIRING PIN ASSEMBLY (A) FROM THE BOLT (B), BY TURNING THE FIRING PIN ASSEMBLY (A) COUNTER-CLOCKWISE.

5 PLACE THE FIRING PIN ASSEMBLY (A) ON A BENCH, AS SHOWN IN FIG. 2, AND PULL DOWN ON THE SLEEVE (C). REMOVE THE PIECE OF METAL (D); GIVE THE COCKING PIECE (E) A QUARTER TURN COUNTERCLOCKWISE AND REMOVE. CAUTION: KEEP A FIRM GRIP ON SLEEVE (C), AS THE SPRING (F) WILL BE COMPRESSED AND HAVE A TENDENCY TO EXPEL THE SLEEVE RAPIDLY. REMOVE THE SLEEVE (C), THE MAIN SPRING (F), AND STRIKER (G).

6 SIGHT DOWN STRIKER (G) REVOLVING IT SLOWLY TO INSPECT IT FOR STRAIGHTNESS. ALSO INSPECT THE FIRING POINT AT (H) WHICH MUST BE SMOOTH AND ROUNDED. REPLACE STRIKER IF NECESSARY.

7 THE CORNER (I) ON COCKING PIECE (E) MUST BE SQUARE AND NOT ROUNDED OR MUTILATED. STONE DOWN ALL NICKS OR ERUPTIONS. ALSO REMOVE ALL RUST SPOTS.

8 INSPECT SLEEVE (C) FOR BURRS AND DISTORTIONS. COCKING PIECE (E) MUST ACTUATE IN SLEEVE FREELY

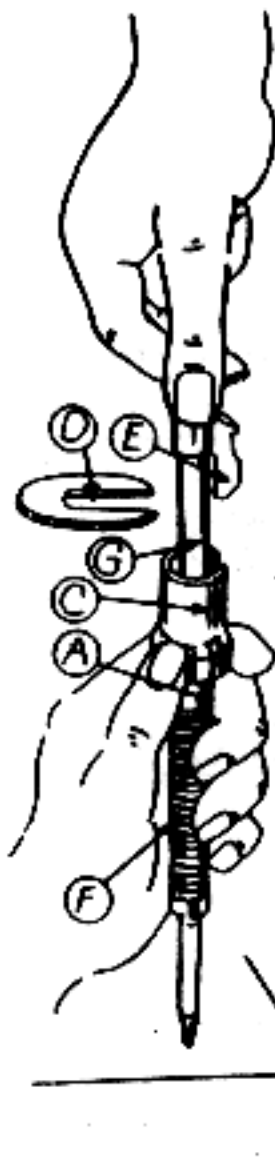

FIG. 2

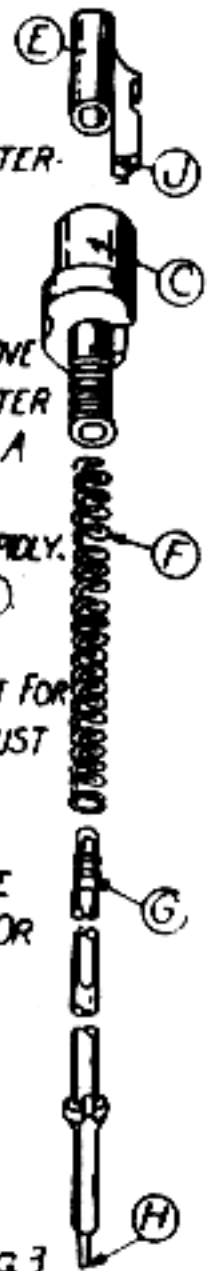

FIG. 3

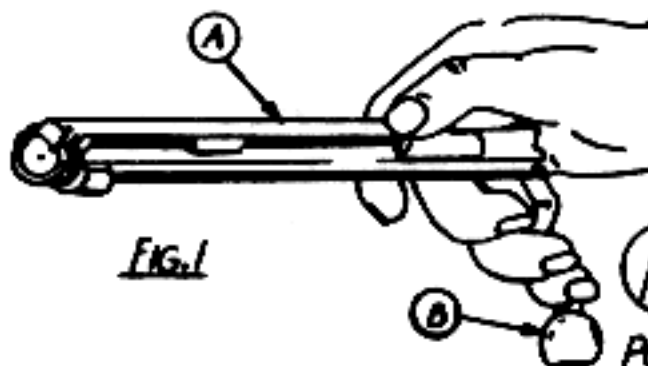

FIG. 1

9 ROTATE EXTRACTOR (A) COUNTER-CLOCKWISE ONE HALF TURN, AND, PUSHING IT FROM THE REAR, AS SHOWN, REMOVE THE EXTRACTOR (A) FROM THE BOLT (B).

10 REMOVE THE BOLT STOP SCREW (C), AND LIFT OFF THE BOLT STOP ASSEMBLY (D). PULL THE SPRING SEAT (E) OUTWARD TO REMOVE.

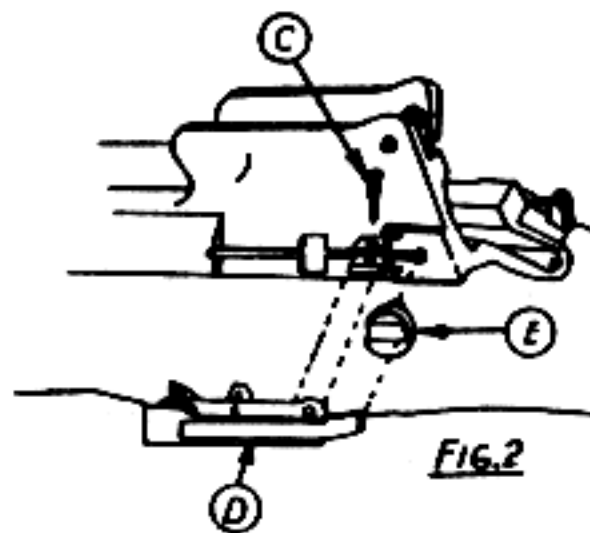

FIG. 2

BOLT STOP SPRING (F) SHOULD HAVE A SLIGHT CURVE FOR TENSION. ALSO THE LIPS (H) MUST BE IN GOOD CONDITION.

11 INSPECT BOLT STOP (H) FOR WEAR AND MUTILATIONS. NOTE THAT BOLT STOP LUG (J) IS NOT DISTORTED. IF NECESSARY REPLACE WITH A NEW ONE.

NOTE THE AMOUNT OF SPRING TENSION ON THE SPRING PORTION (K) OF EJECTOR (G). INSPECT THE EJECTOR FACE (L) FOR DISTORTION. OFTEN REPLACEMENT OF EJECTOR IS NECESSARY.



FIG. 3

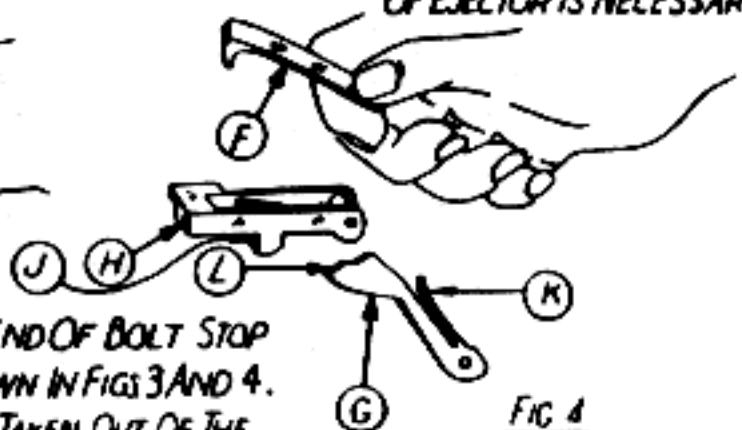
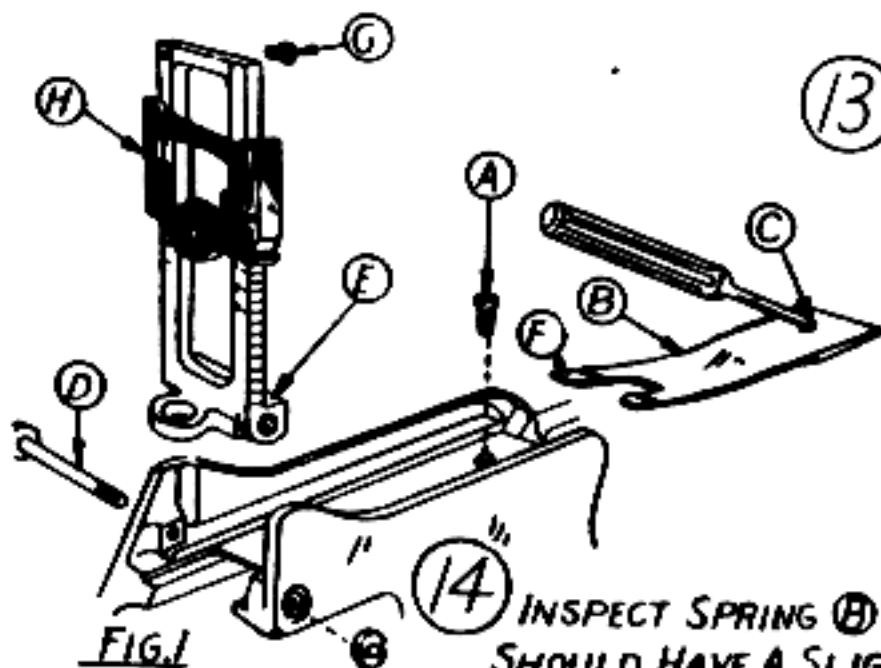

FIG. 4

12 PULL DOWNWARD ON THE FREE END OF BOLT STOP SPRING (F) TO REMOVE, AS SHOWN IN FIGS 3 AND 4. THE RELEASED EJECTOR (G) CAN THEN BE TAKEN OUT OF THE BOLT STOP (H).



- 13 UNSCREW THE BASE SPRING SCREW (A) AND USING A PUNCH, TAP THE REAR SIGHT BASE SPRING (B) FORWARD AT POSITION (C). UNSCREW THE JOINT BOLT (D) AND LIFT OUT THE REAR SIGHT LEAF (E) AS SHOWN.

- 14 INSPECT SPRING (B) FOR BROKEN LIPS (F). SPRING SHOULD HAVE A SLIGHT BOW.

- 15 THE REAR SIGHT PEEP HOLE HOUSING OF SIGHT LEAF (E) IS TO BE STRAIGHT AND AT RIGHT ANGLES TO THE UPRIGHTS.



- 16 REMOVE REAR SIGHT SLIDE STOP SCREW (G) FROM SIGHT LEAF (E), AND SLIDE OFF THE PEEP SIGHT ASSEMBLY (H).

- 17 TO DISMANTLE THE PEEP SIGHT ASSEMBLY (H), TAP OUT THE CATCH PIN (D), PULL THE CATCH (K) AND THE CATCH SPRING (L) STRAIGHT OUTWARD TO REMOVE.

- 18 INSPECT CATCH SPRING (L). ALSO INSPECT THE SLIDE STOP CATCH (K). SPRING (L) MUST BE STRONG ENOUGH TO OPERATE STOP CATCH. THE POINT OF STOP CATCH (K) MUST BE SHARP ENOUGH TO HOLD SIGHT ASSEMBLY SECURE ON UPRIGHT. REPLACE PART IF NECESSARY.

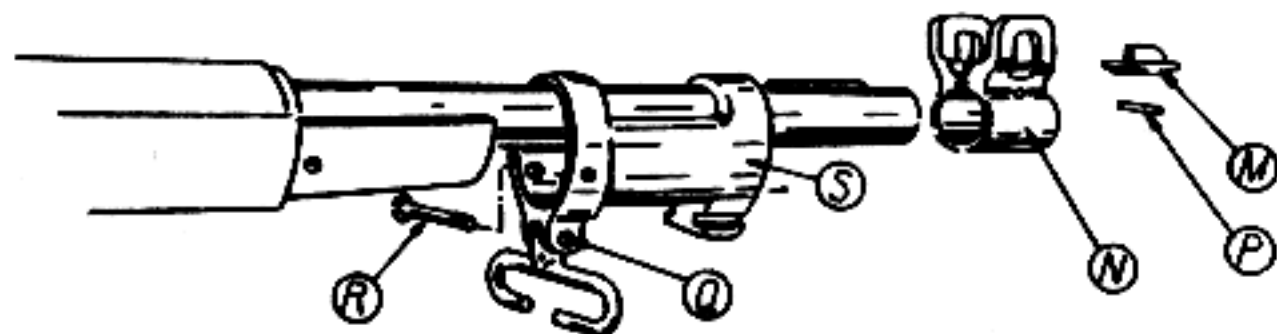
SMALL ARMS
USRIFLE
M1917G.30DISMANTLING
USRIFLE M1917SHEET
5
OF 13

- 19 USING A PUNCH, TAP THE BASE LUG (M) ON THE FRONT SIGHT TO DRIVE IT OUT OF THE FRONT SIGHT CARRIER (N). TAP OUT THE FRONT SIGHT CARRIER PIN (P), AND DRIVE OFF THE FRONT SIGHT CARRIER (N) WITH A SOFT HAMMER.
- 20 LOOSEN THE STACKING SWIVEL SCREW (Q) TO RELIEVE TENSION; REMOVE THE UPPER BAND SCREW (R), AND PULL THE UPPER BAND (S) OFF IN THE DIRECTION SHOWN.
- 21 INSPECT THE FRONT SIGHT BASE LUG (M) FOR WEAR, ALSO FOR BURRS AND RUST SPOTS.
- 22 INSPECT THE FRONT SIGHT CARRIER (N) FOR WEAR AND DISTORTION.

SMALL ARMS
U.S. RIFLE
M1917 & 30

DISMANTLING
U.S. RIFLE M1917

SHEET
6
OF 13

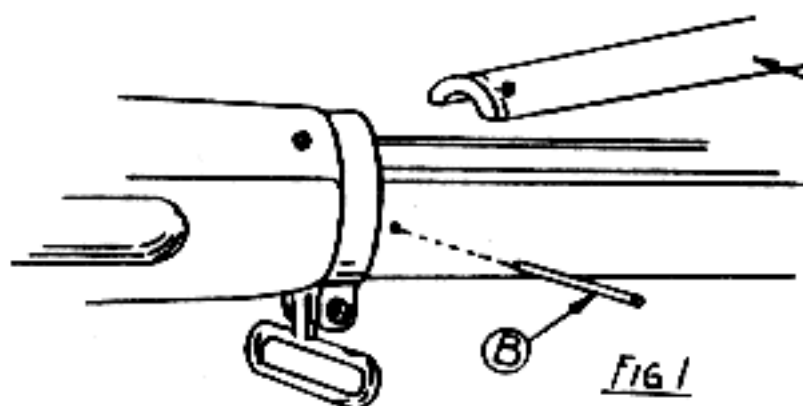

(23) PULL THE HAND GUARD (A) STRAIGHT FORWARD TO REMOVE. TAP OUT THE LOWER HAND PIN (B).

FIG. 1

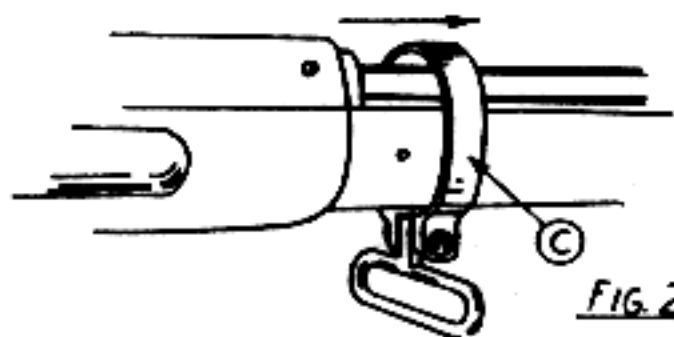

(24) REMOVE THE LOWER BAND (C) AS SHOWN.

FIG. 2

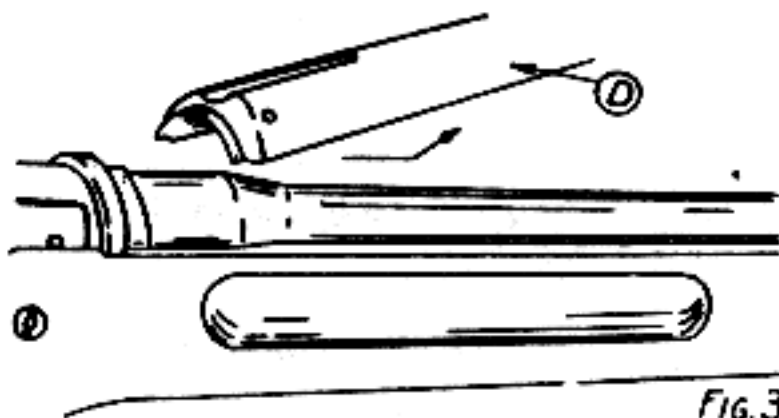

(25) PULL THE REAR HAND GUARD (D) OFF AS SHOWN.

FIG. 3

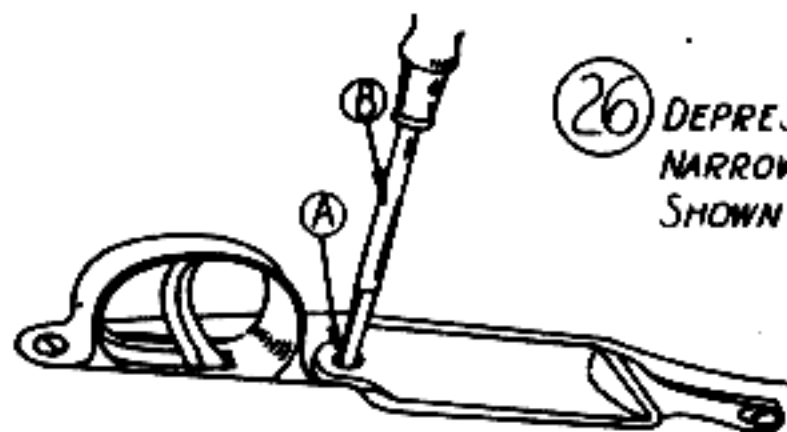
SMALL ARMS
US RIFLE
M1917-42DISMANTLING
US RIFLE M1917SHEET
7
OF 13

- 26 DEPRESS THE FLOOR PLATE CATCH (A) WITH NARROW POINTED SCREWDRIVER (B) AS SHOWN IN FIG. 1.

FIG. 1

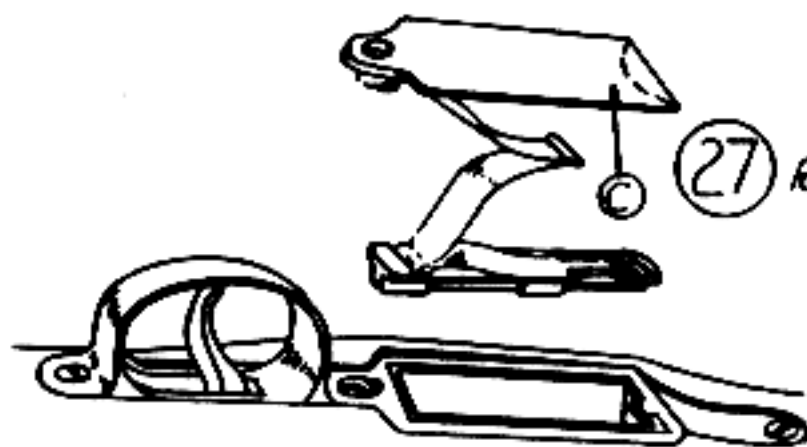

- 27 REMOVE THE FLOOR PLATE ASSEMBLY (C).

FIG. 2

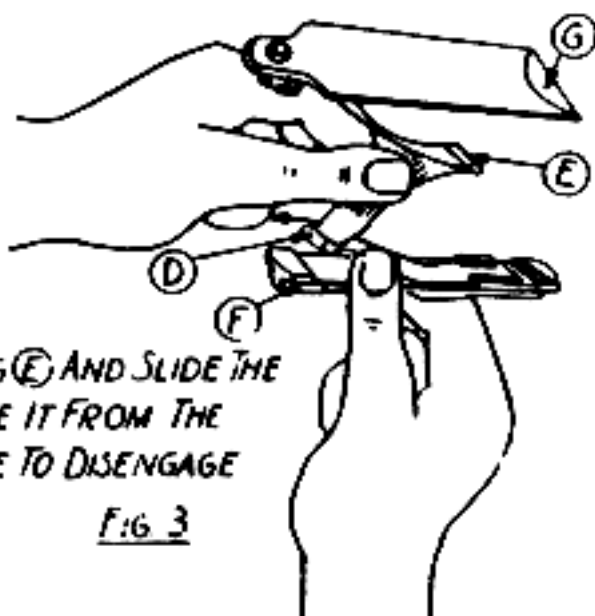

- 28 RAISE THE END (D) ON THE MAGAZINE SPRING (E) AND SLIDE THE SPRING (E) TO REAR AS SHOWN, TO DISENGAGE IT FROM THE FOLLOWER (F). FOLLOW SAME PROCEDURE TO DISENGAGE THE SPRING FROM FLOOR PLATE (G).

FIG. 3

USR-M1917DISM-7(13)

SMALL ARMS

US RIFLE

M1917-24 30

DISMANTLING

US RIFLE M1917

SHEET

8

OF 13

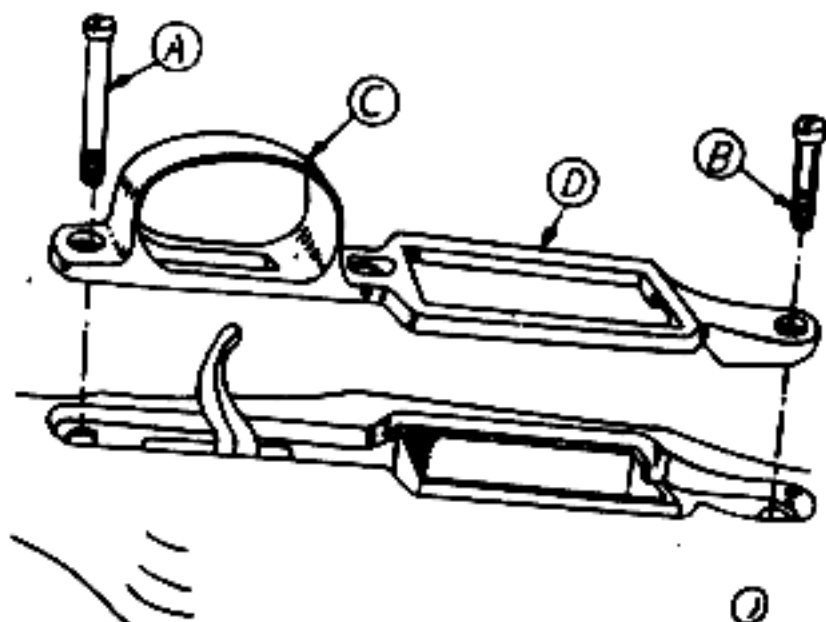

FIG. 1

- 29 UNSCREW THE FRONT GUARD SCREW (A), AND THE REAR GUARD SCREW (B). GRASP THE BOW (C) AND REMOVE THE GUARD (D).

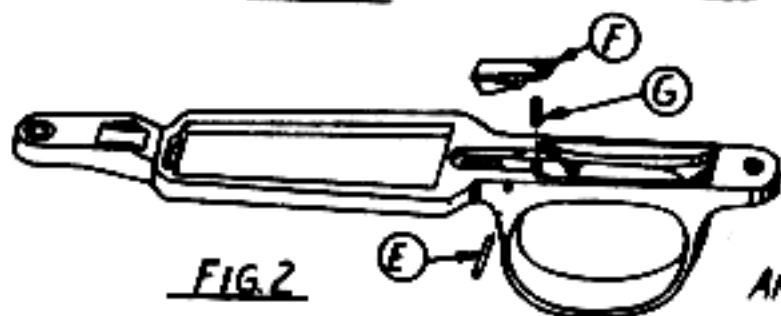

FIG. 2

- 30 PULL OUT THE FLOOR PLATE CATCH PIN (E) AND REMOVE THE FLOOR PLATE CATCH (F) AND THE FLOOR PLATE CATCH SPRING (G).

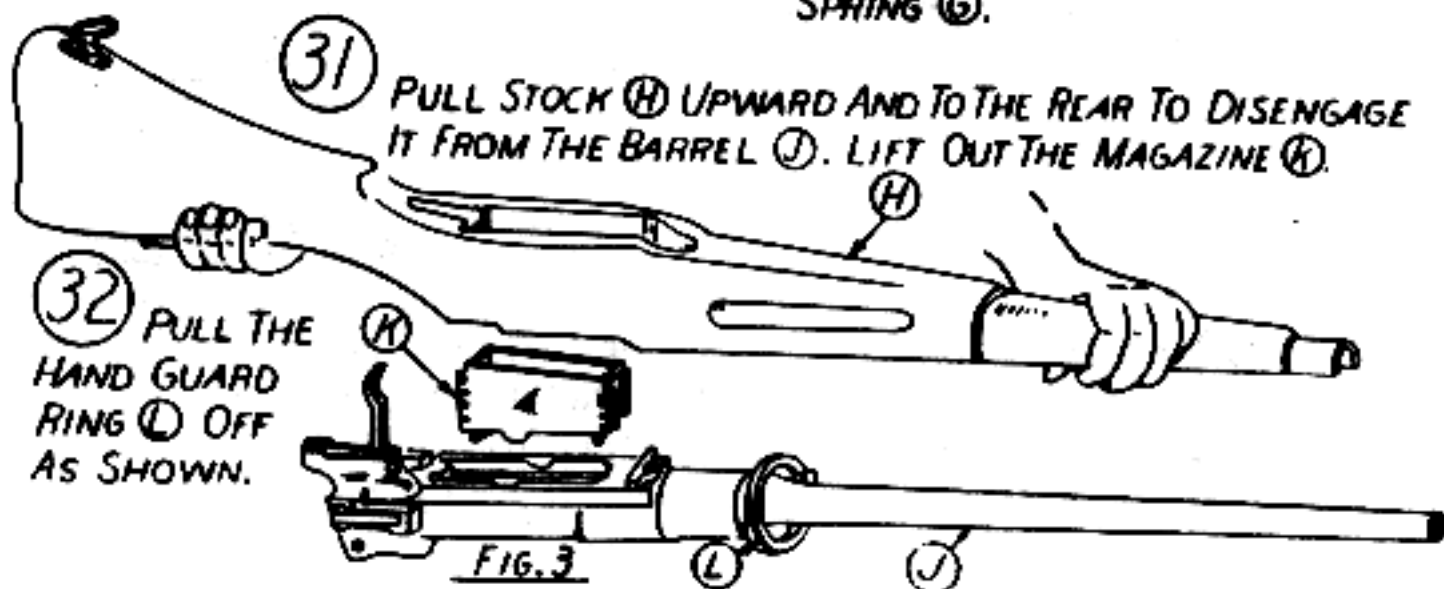
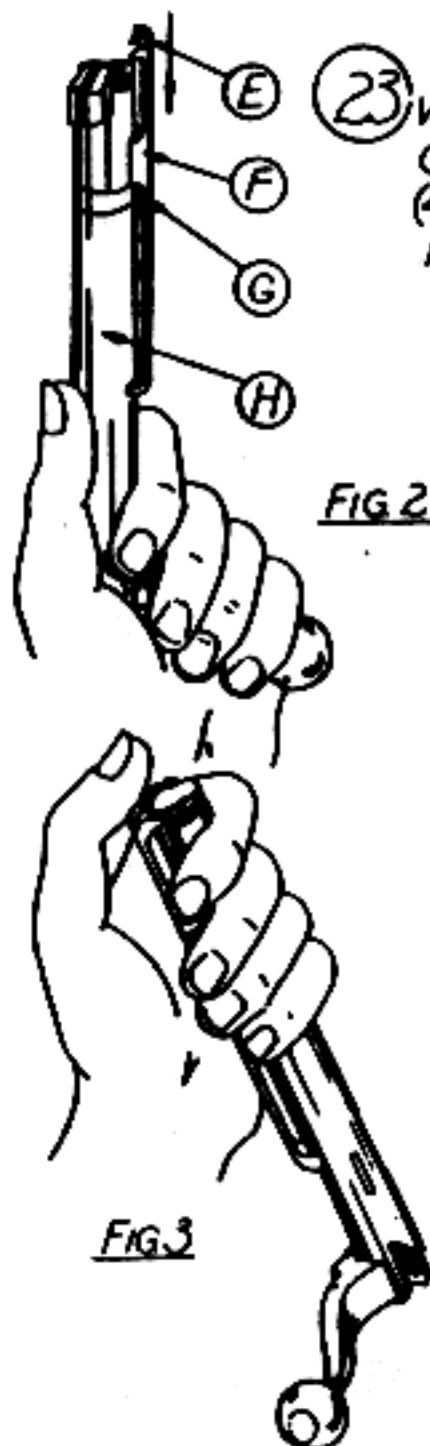
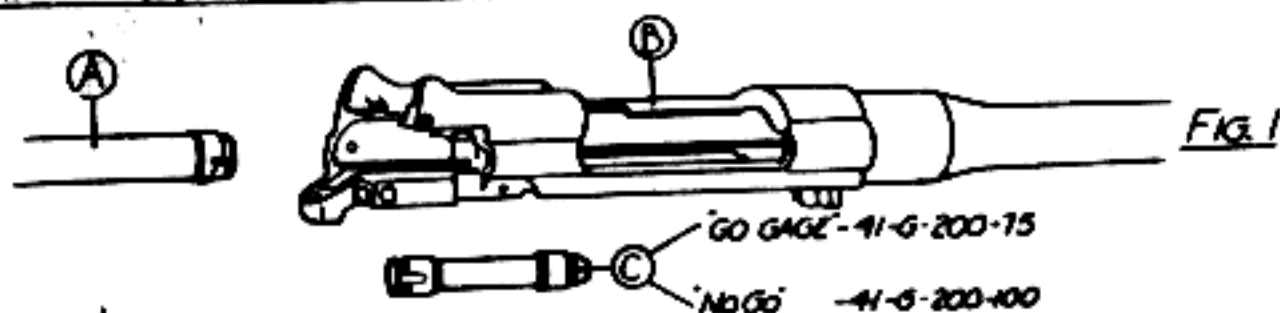

FIG. 3

- 31 PULL STOCK (H) UPWARD AND TO THE REAR TO DISENGAGE IT FROM THE BARREL (J). LIFT OUT THE MAGAZINE (K).
- 32 PULL THE HAND GUARD RING (L) OFF AS SHOWN.

SMALL ARMS
U.S. RIFLE
M1917 CAL. 30ASSEMBLING
U.S. RIFLE, M1917SHEET
9
OF 14

23. SELECT A BARREL AND RECEIVER ASSEMBLY (B) FIG. 1 IN WHICH THE HEADSPACE IS CORRECT IN ACCORDANCE WITH OPERATION 41 OF DISMANTLING. INSERT GO GAGE (C) (41-G-200-75) IN CHAMBER. BOLT (A) SHOULD CLOSE. INSERT NO GO GAGE 41-G-200-100. BOLT SHOULD NOT CLOSE.

24. INSPECT THE LIDS (E) OF EXTRACTOR (F), NOTING THEIR CONDITION AS TO WEAR AND MUTILATIONS. EXTRACTOR (F) SHOULD HAVE A SLIGHT BEND, GIVING IT SPRING TENSION.

INSPECT THE SHELL SEAT IN BOLT (H). STONE DOWN ALL HIGH SPOTS AND REMOVE ALL DUST.

NOTE: THE EJECTION OF SHELLS IS A VERY IMPORTANT OPERATION, THEREFORE EXTRACTOR (F) AND BOLT (H) SHOULD BE INSPECTED VERY THOROUGHLY.

25. SLIDE THE EXTRACTOR (F) ONTO THE LUG (G) AS SHOWN IN FIG. 2. GRASP THE BOLT AS SHOWN IN FIG. 3 AND PUSH THE EXTRACTOR DOWN WITH THE THUMB.

USA
U.S. RIFLE, M1917-ASSEMBLING

SMALL ARMS
 USRIFLE
 M1917 CAL.30

ASSEMBLING
 USRIFLE M1917

SHEET
 10
 OF 19

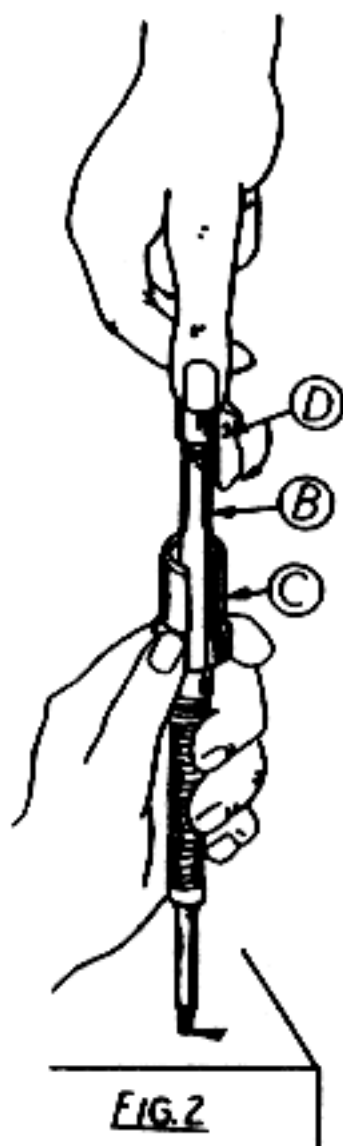

(26) PLACE THE SPRING (A) ON THE STRIKER (B), FOLLOWED BY THE SLEEVE (C). COCKING PIECE ASSEMBLED IN FOLLOWING OPERATION.

(27) GRASP THE SLEEVE (C) AND PULL DOWN, AS IN FIG. 2. PLACE THE COCKING PIECE (D) OVER THE END OF THE STRIKER (B) AS SHOWN, AND TURN CLOCKWISE.

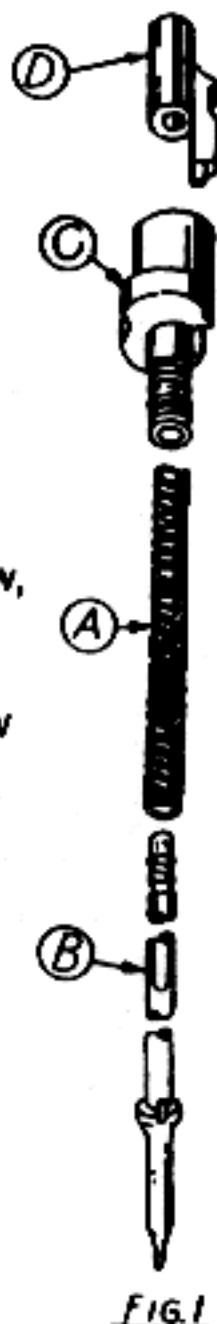

SMALL ARMS USDIFLE M1917 CAL 30	<u>DISMANTLING</u> USDIFLE M1917	SHEET 11 OF 13
---------------------------------------	--	-----------------------------

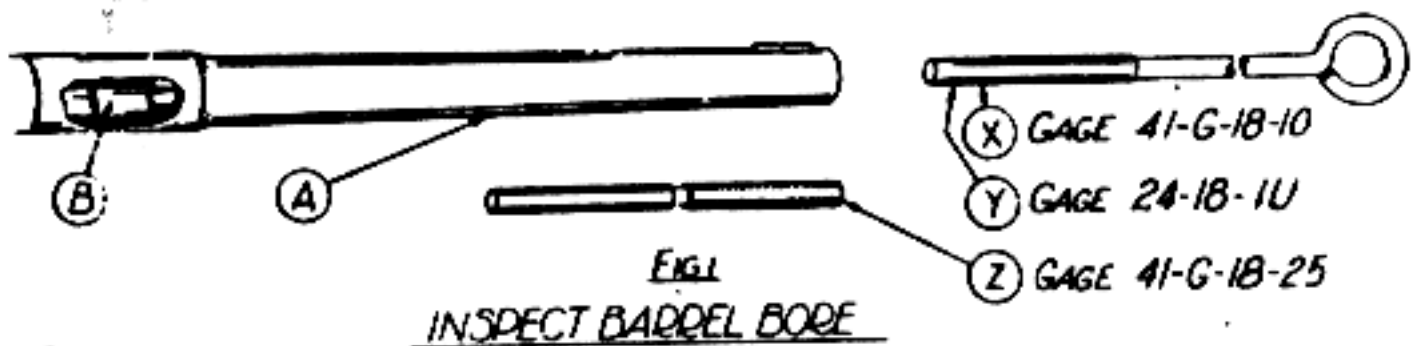

40 SIGHT THROUGH BARREL (A) FROM BOTH ENDS OBSERVING CONDITION OF BORE AND IF FOLLOWING DEFECTS ARE PRESENT, REPLACE WITH NEW BARREL:

- (a) BENT BARREL.
- (b) PITTED AREAS LARGER THAN $\frac{5}{16}$ " IN SIZE ON LANDS OR GROOVES
- (c) PITTED AND DAMAGED SHELL CHAMBER (B)
- (d) IF BORE AT BREECH END IS LARGER THAN $.306$ " (INSERT GAGE (C) THROUGH RECEIVER (D) INTO BORE AND READ DOWN AT (E) IN LINE WITH SURFACE (E). NUMBER 6 ON GAGE DESIGNATES $.306$ " MAXIMUM LIMIT)
- (e) IF MAXIMUM GAGE (Z) ($.302$ ") FITS LOOSELY IN BORE AT MUZZLE END.

THE BORE IS CORRECT IF GAGE (X) ($.300$ ") ENTERS THE ENTIRE LENGTH OF BARREL. IF GAGE (X) WILL NOT ENTER, THE MINIMUM GAGE (Y) ($.2998$ ") SHOULD GO THROUGH OR BORE MUST BE LAPPED. DUST IN BORE MAY BE REMOVED WITH OILED WIRE BRUSH

NOTE: REMOVE RECEIVER FROM BARREL (OPERATION #45) IF BARREL IS DEFECTIVE

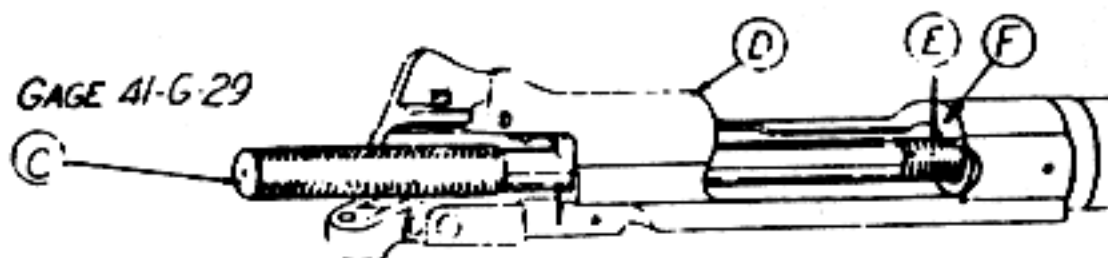

FIG 2

USD-M1917-DEM 11 (13)

SMALL ARMS

USDIFLE
M1917 CAL 30

DISMANTLING

USDIFLE M1917

SHEET

12

OF 13

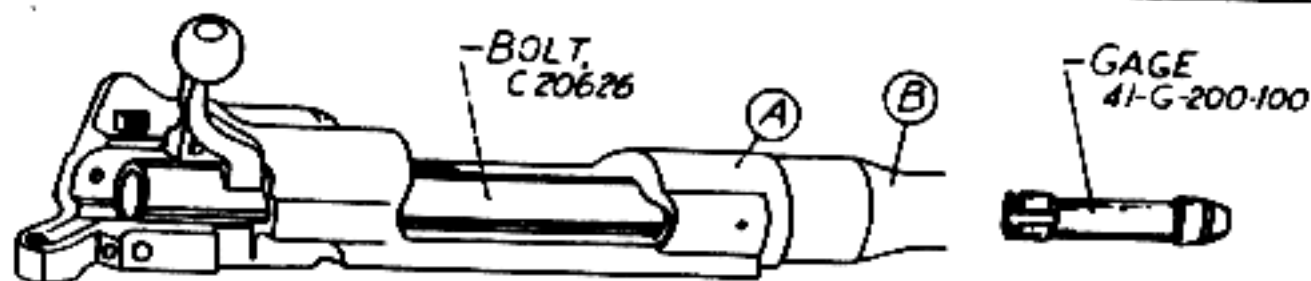

FIG. 1

CHECKING THE HEADSPACE

41 IF THE BORE OF BARREL (B) IS SATISFACTORY AS INDICATED IN PREVIOUS OPERATION AND IF RECEIVER (A) IS SERVICEABLE, CHECK THE SHELL CHAMBER IN THE BARREL FOR CORRECT HEADSPACE WHILE THE BARREL IS ASSEMBLED TO RECEIVER. THIS IS DETERMINED WITH THE AID OF A TEST BOLT AND HEADSPACE GAGES, AS PRESCRIBED:

- WITH HEADSPACE GAGE 41-G-200-100 INSIDE THE SHELL CHAMBER, TEST BOLT ORD DWS, NC C 20626 SHOULD NOT CLOSE FULLY. IF THE TEST BOLT CLOSES FREELY ON THIS HEADSPACE GAGE, EXCESSIVE HEADSPACE DUE TO WEAR IS INDICATED. IN THIS CASE REPLACE THE BARREL, EITHER WITH NEW OR SERVICEABLE BARREL (REFER TO SHEET NO 1 OF SECTION 2) THEN CHECK THE HEADSPACE. NOTE BARRELS HAVING EXCESSIVE HEADSPACE, YET OTHERWISE SATISFACTORY, MAY BE SALVAGED AT AN ARSENAL BY ADVANCING THE BREECH END AND CHAMBER.
- WITH HEADSPACE GAGE 41-G-200-75 INSIDE THE SHELL CHAMBER, FIELD TEST BOLT SHOULD CLOSE FULLY. IF IT DOES NOT CLOSE FULLY ON HEADSPACE GAGE, AS IN FIG 2, INSUFFICIENT HEADSPACE IS INDICATED THIS MAY OCCUR WHEN A SERVICEABLE, OR NEW BARREL IS INSTALLED. NOTE INSUFFICIENT HEADSPACE MAY BE CORRECTED WITH A HAND REAMER (REFER TO OPERATION NO. 42-44).

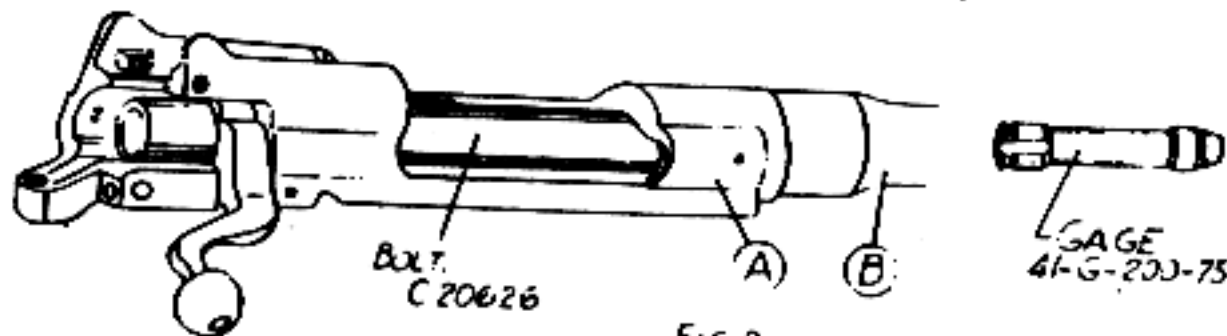
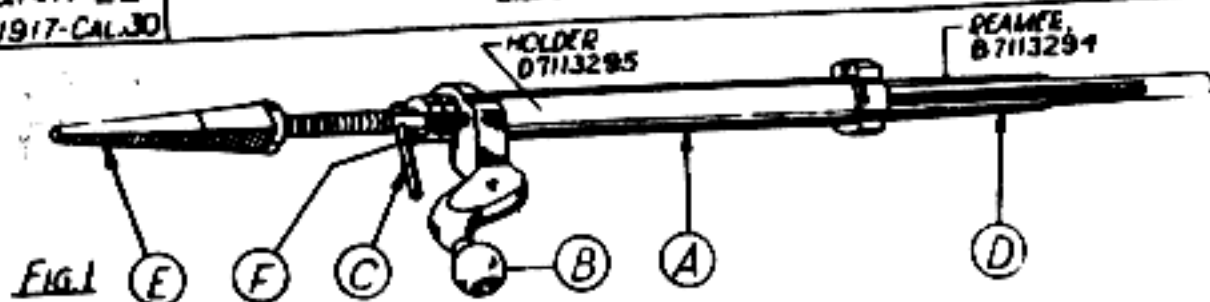

FIG. 2

USD M1917 DISM R(13)

SMALL ARMS US RIFLE M1917-CAL.30	DISMANTLING US RIFLE M1917	SHEET 13 OF 13
--	--------------------------------------	-----------------------------

HEAD SPACE GAGING & REAMING (CONT.)

- 42 INSERT REAMER GUIDE (A) INTO RECEIVER AND PUSH HANDLE (B) DOWN TO LOCKED POSITION. SECURE GUIDE (A) IN PLACE BY TURNING SCREW (C) IN AGAINST RECEIVER.
- 43 LUBRICATE REAMER (D) AND SLIDE IT THROUGH GUIDE (A) INTO THE CHAMBER. TURN REAMER AT (E) WITH A BIT BRACE UNTIL STOP COLLARS (F) ARE AGAINST GUIDE (A).
- 44 REMOVE REAMER AND GUIDE FROM RECEIVER AND CLEAN CHAMBER THOROUGHLY.

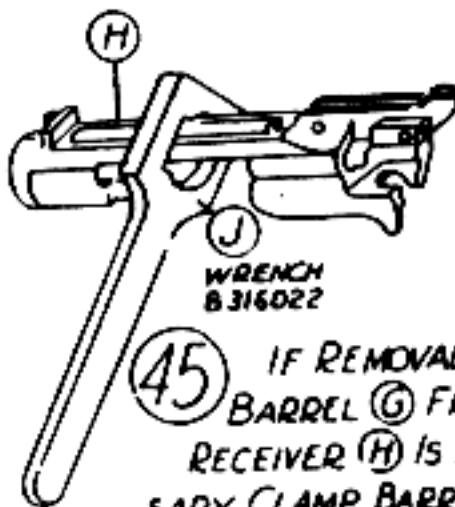
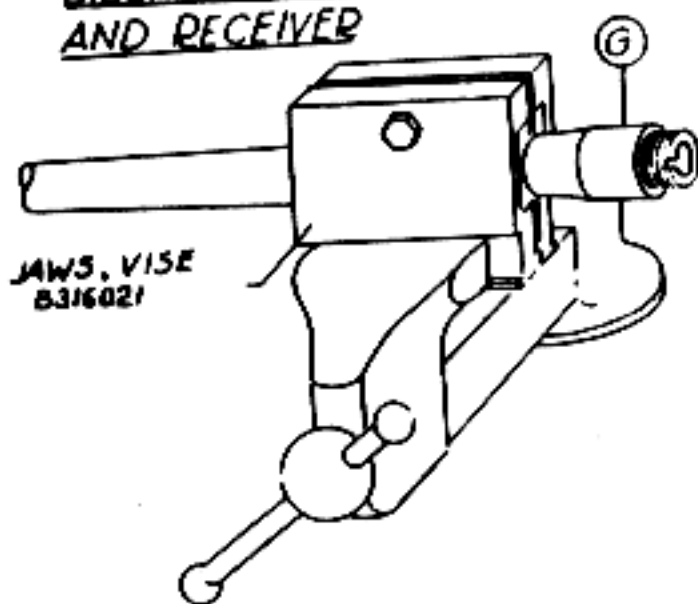
DISENGAGING BARREL AND RECEIVER

- 45 IF REMOVAL OF BARREL (G) FROM RECEIVER (H) IS NECESSARY, CLAMP BARREL TIGHTLY IN VISE JAWS, HAVING FIRST SLIPPED THE SPECIAL WRENCH (J) OVER BARREL AND RECEIVER AS SHOWN UNSCREW RECEIVER (H) FROM BARREL.

USR M1917-DISM-13(13)